



**PUBLIC MEETING NOTICE AND AGENDA  
PARKS AND RECREATION BOARD MEETING**

**FEBRUARY 7, 2019**

**6:30 p.m.**

**AGENDA**

1. Call to Order
2. Roll Call
3. Public Comment on Agenda Items Only
4. Approval of December 6, 2018 Park & Recreation Board Meeting Minutes
5. Old Business
  - A. Goals
6. New Business
  - A. LaBuy Playground Replacement
7. Staff Reports
  - A. Summer Program Survey
8. Trustee Liaison Report
9. Member Comments
10. Audience Participation

The public is invited to make an issue-oriented comment on any matter of public concern not otherwise on the agenda. The public comment may be no longer than 3 minutes in duration.
11. Adjournment

**MEETING LOCATION**

Lake in the Hills Village Hall

600 Harvest Gate

Lake in the Hills, IL 60156

*The Village of Lake in the Hills is subject to the requirements of the Americans with Disabilities Act of 1990. Individuals with disabilities who plan to attend this meeting and who require certain accommodations so that they can observe and/or participate in this meeting, or who have questions regarding the accessibility of the meeting or the Village's facilities, should contact the Village's ADA Coordinator at (847) 960-7410 [TDD (847) 658-4511] promptly to allow the Village to make reasonable accommodations for those persons.*

Posted by: Laura Pekovic

Date: February 5, 2019

Time: 11:00 a.m.



**VILLAGE OF LAKE IN THE HILLS**  
**PARKS & RECREATION BOARD MEETING**  
**December 6, 2018**

The Parks & Recreation Board meeting was called to order at 6:30 p.m. at the Lake in the Hills Village Hall. Those present were Members Andrea, Cairns, Lupo, Wackerlin, and Chairwoman Tredore. Also present were Director of Community Services Fred Mullard, Assistant Director of Parks & Recreation Megan Croy, Recreation Supervisor Kristi Brewer, Trustee Suzanne Artinghelli, and Recording Secretary Laura Pekovic. Member Sandage was absent.

**PUBLIC COMMENT ON AGENDA ITEMS--None**

**APPROVAL OF MINUTES**

A motion to approve the minutes of the Parks & Recreation Board meeting of November 1, 2018 was made by Member Lupo and seconded by Member Wackerlin. The motion was approved by a vote of 5-0.

**OLD BUSINESS – Goals**

Pursuant to the vision on how staff can enhance and improve services within the community, there was an active discussion among Board members and staff regarding the safety of the parks programs and equipment, as well as the uniqueness of Lake in the Hills.

Regarding the “Safe” vision of Lake in the Hills, comments from the Board were that the parks and playgrounds are well maintained, equipped with appropriate warning signs, and a Thoroguard lightening alert system at Sunset Park. It is important that events need to be safe for all with clear exits. Director Mullard explained that there are certified playground inspectors at Public Works who do monthly inspections. They are able to do some immediate repairs or will take a playground piece out of service until a replacement can be installed. Public Works and the Algonquin/Lake in the Hills Fire Department also conduct regular, Village-facility inspections.

In response to a member inquiry, Parks staff described Village safety plans currently in place when hosting programs with children and seniors. Background checks are conducted of all employees who work with children and seniors. Records are safely secured in accordance with DCFS guidelines. Employees receive first aid, driver-safety, and food safety training/certification. Parks and Recreation staff works with the Police Department for event weather-related emergency plans.

Regarding the “Uniquely Lake in the Hills” vision, comments from the Board were that Lake in the Hills has the uniqueness of both open space and water. The airport and fen are also unique. In order to create more of an identity to Lake in the Hills it is important to select programs around these places and advertise as such. The Turtle Island Improvement Project is a good example of this.

Megan Croy reviewed the staff report. The Beyond the Bell program needs staff. Finding a supervisor that has the required skill set has been a challenge. For now, Kristi Brewer has been stepping up to that role in addition to her regular duties. The Letters to Santa program is going well with personalized, handwritten letters being written by the Senior Club members. The Customer Service Division/employee relocation was explained. The former Parks and Recreation office staff area is proposed to be new preschool rooms to replace the Indian Trail Beach location, pending 2019 budget approval.

**NEW BUSINESS--None**

**TRUSTEE LIAISON REPORT--None**

**MEMBER COMMENTS--None**

**AUDIENCE PARTICIPATION--None**

**ADJOURNMENT**

Member Lupo made a motion to adjourn the meeting. Member Wackerlin seconded the motion. The motion was approved by a voice vote of 5-0. The meeting adjourned at 6:30 p.m.

Submitted by  
Laura Pekovic  
Recording Secretary

DRAFT



# INFORMATIONAL MEMORANDUM

---

**MEETING DATE:** February 7, 2019  
**DEPARTMENT:** Community Services  
**SUBJECT:** Vision

## EXECUTIVE SUMMARY

---

The National Recreation and Parks Association suggest that the organization have a vision statement that is inspirational, far-reaching, and states where the organization is going. At each scheduled Parks and Recreation Board meeting, staff will discuss with the Parks and Recreation Board the vision to enhance and improve services provided to the community. The Board is encouraged to share and incorporate into the discussion any feedback received from residents, information from visiting playgrounds and facilities in Lake in the Hills and other communities, or trending ideas from a variety of media. Attached is the summary of what we have already discussed.

This month's point for discussion, also our final points, is "TRANSPARENT and A GOOD INVESTMENT."

## FINANCIAL IMPACT

---

None

## ATTACHMENTS

---

None

## SUGGESTED DIRECTION

---

Conduct an active discussion of how TRANSPARENT and A GOOD INVESTMENT are a part of the Village's Parks and Recreation activities.



# Parks and Recreation Vision



## Open To All

Create greater access to quality programming and facilities for those who have been traditionally underserved by showcasing parks, facilities, and programs on Facebook, Village website, and seasonal brochures to create interest and increase awareness of Village services



## Relevant and Diverse

Create greater access to quality programming and facilities for those who have been traditionally underserved.



## Healthy

Provide residents and non-residents structured and self-initiated opportunities to get outdoors, move their bodies, and enjoy leisure activities.



## Green

Be excellent stewards of the environment and resources through education and programs that favor the natural environment and actions that support long-term sustainability.



## Strategic and Productive

Apply due diligence in planning, executing, and evaluation all activities through clearly established goals, detailed program analysis, and efficient use of resources to meet the needs of the Village's residents.



## Safe

Create a culture where safety of participants and staff is a key consideration in event planning & operations, park and facility operation & maintenance, and staff & volunteer training . Prepare for potential natural and manmade hazards and maintain a reporting structure for observed defects.



## Uniquely LITH

Create programs that celebrate and differentiate Lake in the Hills from others by considering the traditions, historic, cultural, and natural beauty that is Lake in the Hills. Make the residents our primary source of ideas and feedback.



## Transparent



## A Good Investment



# INFORMATIONAL MEMORANDUM

---

**MEETING DATE:** February 7, 2019  
**DEPARTMENT:** Community Services  
**SUBJECT:** LaBuy Playground Replacement RFP

## EXECUTIVE SUMMARY

---

A Request for Simplified Proposal was put out asking for renderings for the upcoming LaBuy Playground replacement. Nine submissions were received from five different vendors. These vendors were asked to attend a public focus group to present their renderings and receive resident feedback. With resident, staff, and parks and Recreation Board input, we will select three vendors to complete a final request for Proposal.

## FINANCIAL IMPACT

---

None

## ATTACHMENTS

---

Renderings received from Burke, Cunningham, NuToys, Parkreation, and Team Reil.

## SUGGESTED DIRECTION

---

The Board is asked to provide input, while considering resident and staff feedback, to assist in selecting three vendors to move forward in the bid process.

# Village of Lake in the Hills Park & Recreation La Buy Park

Proposal # 129-114919-1  
January 22, 2019

Presented by  
Play Illinois, LLC



# Burke®



January 22, 2019

Jerry Marsh  
Village of Lake in the Hills Park & Recreations  
9010 Haligus Road  
Lake in the Hills, IL 60156

Dear Jerry Marsh:

Play Illinois, LLC is delighted to provide Village of Lake in the Hills Park & Recreations with this playground equipment proposal.

This design was developed with your specific needs in mind, and we look forward to discussing this project further with you to ensure your complete satisfaction. Play Illinois, LLC is confident that this proposal will satisfy Village of Lake in the Hills Park & Recreations's functional, environmental, and safety requirements -- and most importantly -- bring joy and excitement to the children and families directly benefiting from your new playground.

You have our personal commitment to support this project and your organization in every manner possible, and we look forward to continue developing a long-standing relationship with Village of Lake in the Hills Park & Recreations. We appreciate your consideration and value this opportunity to earn your business.

Sincerely,

Cheryl Parson  
Play Illinois, LLC  
4716 Roslyn Rd.  
Downers Grove, IL 60515



## **Design Summary**

Play Illinois, LLC is very pleased to present this Proposal for consideration for the La Buy Park located in Lake in the Hills. BCI Burke Company, LLC has been providing recreational playground equipment for over 90 years and has developed the right mix of world-class capabilities to meet the initial and continuing needs of Village of Lake in the Hills Park & Recreations. We believe our proposal will meet or exceed your project's requirements and will deliver the greatest value to you.

The following is a summary of some of the key elements of our Proposal:

- Project Name: La Buy Park
- Project Number: 129-114919-1
- User Capacity: 90
- Age Groups: Ages 5-12 years
- Dimensions: 74' 2" x 49' 4"
- Designer Name: Maggie Colton

Play Illinois, LLC has developed a custom playground configuration based on the requirements as they have been presented for the La Buy Park playground project. Our custom design will provide a safe and affordable playground environment that is aesthetically pleasing, full of fun for all users and uniquely satisfies your specific requirements. In addition, proposal # 129-114919-1 has been designed with a focus on safety, and is fully compliant with ASTM F1487 and CPSC playground safety standards.

We invite you to review this proposal for the La Buy Park playground project and to contact us with any questions that you may have.

Thank you in advance for giving us the opportunity to make this project a success.

# Burke®

SERIES: Basics, Intensity, Nucleus

SITE PLAN

DRAWN BY: Maggie Colton

La Buy Park

35 Hilltop Drive

Lake in the Hills, IL 60156

BCI Burke Company, LLC PO Box 549 Fond du Lac, Wisconsin 54936-0549 Telephone 920-921-9220

January 22, 2019

Play Illinois, LLC

129-114919-1

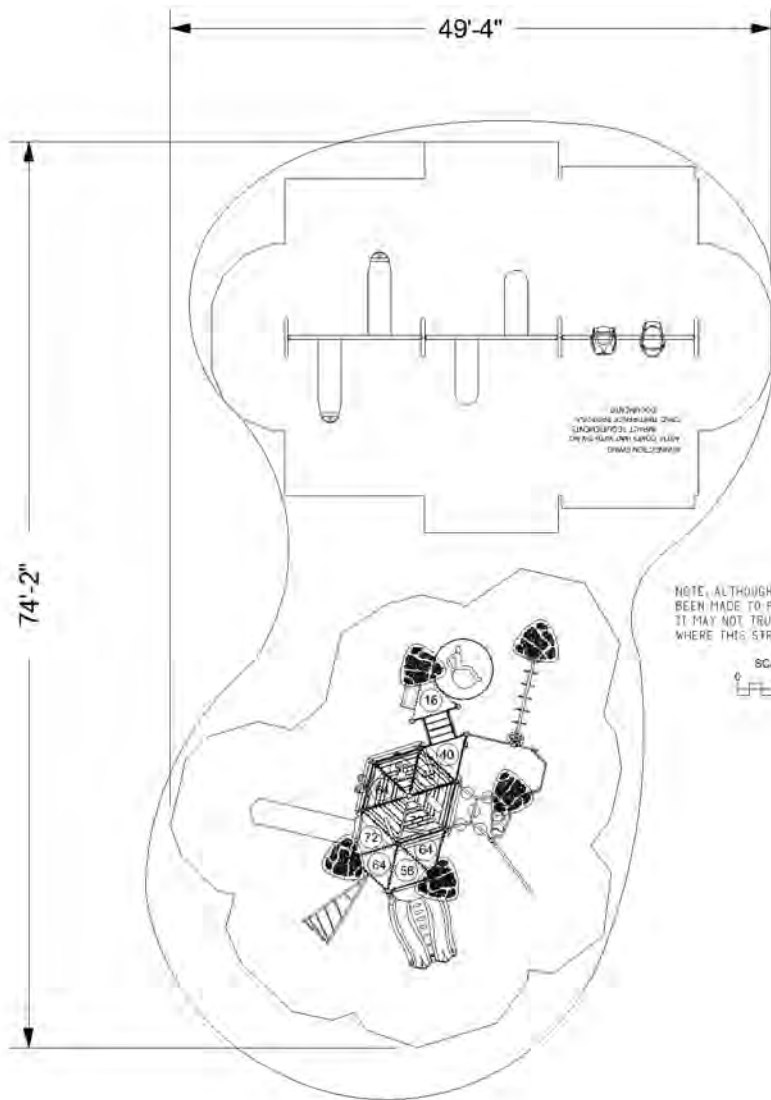

NOTE: ALTHOUGH ALL ATTEMPTS HAVE BEEN MADE TO PROVIDE AN ACCURATE SITE IT MAY NOT TRULY REPRESENT THE AREA WHERE THIS STRUCTURE IS TO BE PLACED.

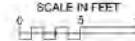

### ADA ACCESSIBILITY GUIDELINE (ADAAG CONFORMANCE)

NUMBER OF PLAY EVENTS:	19		
NUMBER OF ELEVATED PLAY EVENTS:	9		
NUMBER OF ELEVATED PLAY EVENTS ACCESSIBLE BY RAMP:	PROVIDED: 0	REQD: 0	
NUMBER OF ELEVATED PLAY EVENTS ACCESSIBLE BY TRANSFER SYSTEM:	PROVIDED: 9	REQD: 9	
NUMBER OF ELEVATED PLAY EVENTS ACCESSIBLE BY RAMP OR TRANSFER SYSTEM:		REQD: 5	
NUMBER OF GROUND LEVEL PLAY EVENTS:	PROVIDED: 10	REQD: 3	
NUMBER OF TYPES OF GROUND LEVEL PLAY EVENTS:	PROVIDED: 4	REQD: 3	

### WARNING!

ACCESSIBLE SAFETY SURFACING MATERIAL IS REQUIRED BENEATH AND AROUND THIS EQUIPMENT.

FOR SLIDE FALL ZONE SURFACING AREA SEE CPSC's Handbook for Public Playground Safety.

PLATFORM HEIGHTS ARE IN INCHES ABOVE RESILIENT MATERIAL.

INFORMATION  
MINIMUM FALL ZONE  
SURFACED WITH  
RESILIENT MATERIAL  
AREA

2126 SQ.FT.

PERIMETER

279 FT.

STRUCTURE SIZE

74' 2" x 49' 4"

STRUCTURE IS DESIGNED  
FOR CHILDREN AGES:

- 6-23 MONTH OLDS
- 2-5 YEAR OLDS
- 5-12 YEAR OLDS
- 13 + YEAR OLDS



Registered  
to ISO 9001



Registered  
to ISO 14001



To verify product certification,  
visit [www.ipema.org](http://www.ipema.org)

The play components identified  
in this plan are IPEMA  
certified. The use and layout of  
these components conform to the  
requirements of ASTM F1487.  
To verify product certification,  
visit [www.ipema.org](http://www.ipema.org)

The space requirements shown  
here are to ASTM standards.  
Requirements for other standards  
may be different.

The use and layout of play  
components identified in this plan  
conform to the CPSC guidelines.  
U.S. CPSC recommends the  
separation of age groups in  
playground layouts.

ITEM	COMP.	DESCRIPTION
1	270-0001	OFFSET ENCLOSURE
2	270-0050	8" CLOSURE PLATE
3	270-0112	UNITARY ENCLOSURE
4	270-0129	TRIANGLE PLATFORM
5	270-0132	HALF HEXAGON PLATFORM
6	270-0231	24" PLATFORM TO PLATFORM B
7	370-0016	GRAB BAR ASSEMBLY
8	370-0313	SINGLE STEP
9	370-0467	24" TRANSITION STAIR W/BARRI
10	370-0549	CENTER MOUNT TWIST N' TURN
11	370-0564	MOUNTAIN TOP CLIMBER 64"
12	370-0710	TRIANGLE TRAVERSE
13	370-0763	ODYSSEY DECK LINK
14	370-0778	CLUBHOUSE LEAF CLIMBER 64"
15	370-0810	POWER PEAK W/ PANELS
16	370-0863	TREE BRANCH CLIMBER 56"
17	370-0868	TREE BRANCH CLIMBER-4
18	370-1592	PODSTEP CLIMBER 64-72"
19	370-1608	OVISTEP LAUNCH PAD
20	470-0101	DYNAMIC PAD
21	470-0638	CLUBHOUSE HEX ROOF
22	470-0753	VELO SLIDE, 64"-72"
23	470-0755	LUGE SLIDE, 48"-56"
24	470-0764	POST TOPPER, SOLO SHEET
25	550-0100	TOT SEAT, 7' & 8' PAIR, STD CH
26	550-0112	BELT SEAT, 8' PAIR, STD CHAIN
27	550-0158	3 1/2" OD ARCH SWING
28	550-0159	3 1/2" OD ARCH SWING ADD-ON
29	550-0171	FREEDOM SWING SEAT, 8' BEAM
30	550-0191	KONNECTION SWING
31	570-1858	3-IN-A-ROW PANEL, ABOVE PLAT

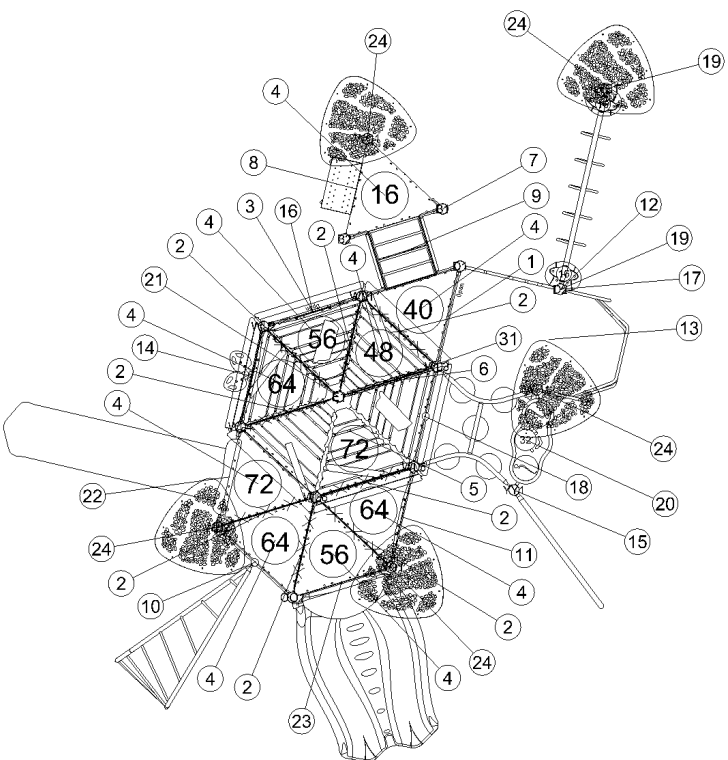
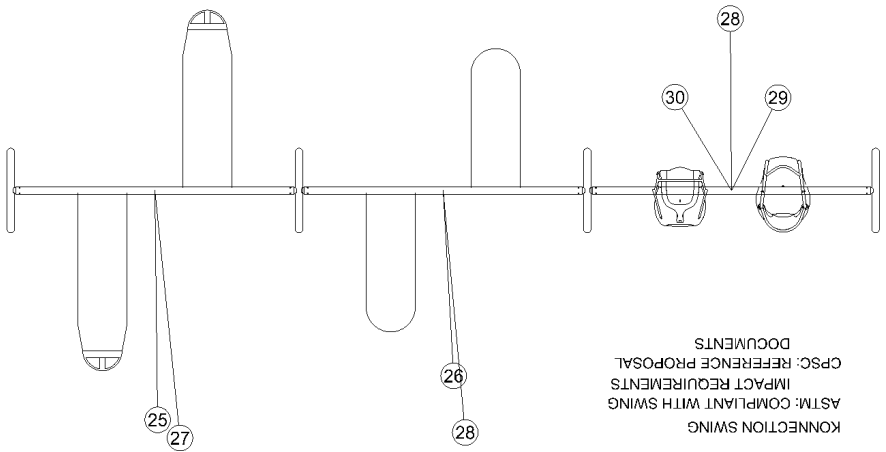

**Burke**

SERIES: Basics, Intensity, Nucleus  
COMPONENT PLAN  
DRAWN BY: Maggie Colton

BCI Burke Company, LLC PO Box 549 Fond du Lac, Wisconsin 54936-0549 Telephone 920-921-9220

La Buy Park  
35 Hilltop Drive  
Lake in the Hills, IL 60156

Play Illinois, LLC  
129-114919-1

January 22, 2019



The protective surfacing for this design must accomodate the critical fall height.

**Burke**

SERIES: Basics, Intensity, Nucleus  
ELEVATION PLAN  
DRAWN BY: Maggie Colton

La Buy Park  
35 Hilltop Drive  
Lake in the Hills, IL 60156

BCI Burke Company, LLC PO Box 549 Fond du Lac, Wisconsin 54936-0549 Telephone 920-921-9220

January 22, 2019  
Play Illinois, LLC  
129-114919-1



**Burke**

SERIES: Basics, Intensity, Nucleus  
ISOMETRIC PLAN  
DRAWN BY: Maggie Colton

La Buy Park  
35 Hilltop Drive  
Lake in the Hills, IL 60156

January 22, 2019  
Play Illinois, LLC  
129-114919-1

BCI Burke Company, LLC PO Box 549 Fond du Lac, Wisconsin 54936-0549 Telephone 920-921-9220



# Proposal # 129-114919-1

January 22, 2019  
2019 Pricing

**Proposal Prepared for:**  
Jerry Marsh  
Village of Lake in the Hills  
9010 Haligus Road  
Lake in the Hills, IL 60156

**Project Location:**  
La Buy Park  
35 Hilltop Drive  
Lake in the Hills, IL 60156

**Proposal Prepared by:**  
Play Illinois, LLC  
4716 Roslyn Rd.  
Downers Grove, IL 60515

Cheryl Parson  
Phone: 630-200-8759  
cparson@playil.com

Component No.	Description	Qty.	User Cap.	Ext. User Cap.	Weight	Ext. Weight
<b>Burke Basics (Swing Seats &amp; Chains Only)</b>						
550-0171	FREEDOM SWING SEAT, 8' BEAM, ...	1	1	1	38	38
550-0191	KONNECTION SWING	1	2	2	64	64
<b>Intensity</b>						
370-0710	TRIANGLE TRAVERSE	1	2	2	40	40
370-0868	TREE BRANCH CLIMBER-4	1	4	4	33	33
370-1608	OVISTEP LAUNCH PAD	2	1	2	10	20
470-0101	DYNAMIC PAD	1	2	2	27	27
<b>Nucleus</b>						
270-0001	OFFSET ENCLOSURE	1	0	0	30	30
270-0050	8" CLOSURE PLATE	8	0	0	10	80
270-0112	UNITARY ENCLOSURE	1	0	0	34	34
270-0129	TRIANGLE PLATFORM	9	2	18	48	432
270-0132	HALF HEXAGON PLATFORM	1	6	6	144	144
270-0231	24" PLATFORM TO PLATFORM BARR...	1	0	0	35	35
370-0016	GRAB BAR ASSEMBLY	1	0	0	6	6
370-0313	SINGLE STEP	1	1	1	42	42
370-0467	24" TRANSITION STAIR W/BARRIE...	1	2	2	164	164
370-0549	CENTER MOUNT TWIST N' TURN CL...	1	6	6	115	115
370-0564	MOUNTAIN TOP CLIMBER 64"	1	2	2	106	106
370-0763	ODYSSEY DECK LINK	1	4	4	40	40
370-0778	CLUBHOUSE LEAF CLIMBER 64" - ...	1	6	6	86	86
370-0810	POWER PEAK W/ PANELS	1	8	8	87	87
370-0863	TREE BRANCH CLIMBER 56"	1	2	2	25	25
370-1592	PODSTEP CLIMBER 64-72"	1	10	10	125	125
470-0638	CLUBHOUSE HEX ROOF	1	0	0	335	335
470-0753	VELO SLIDE, 64"-72"	1	2	2	146	146
470-0755	LUGE SLIDE, 48"-56"	1	4	4	198	198
470-0764	POST TOPPER, SOLO SHEET	5	0	0	100	500
570-1858	3-IN-A-ROW PANEL, ABOVE PLATF...	1	2	2	45	45
600-0104	NPPS SUPERVISION SAFETY KIT	1	0	0	3	3
670-0002	POST ASSEMBLY 5" OD X 107"	2	0	0	58	116
670-0099	INSTALLATION KIT, INTENSITY	1	0	0	2	2
670-0103	MAINTENANCE KIT, INTENSITY	1	0	0	0	0
670-0158	POST ASSEMBLY 5" OD X 184"	1	0	0	97	97
670-0161	POST, SWAGED ROOF 5" OD X 171"	1	0	0	90	90
670-0164	POST, SWAGED ROOF 5" OD X 158"	1	0	0	83	83
670-0166	POST ASSEMBLY 5" OD X 139"	2	0	0	74	148
670-0167	POST ASSEMBLY 5" OD X 147"	1	0	0	78	78
670-0169	POST ASSEMBLY 5" OD X 171"	1	0	0	91	91



# Proposal # 129-114919-1

January 22, 2019  
2019 Pricing

670-0398	POST, SWAGED ROOF 5" OD X 184"	2	0	0	96	192
670-0399	POST, SWAGED ROOF 5" OD X 206"	6	0	0	103	618
670-0418	POST, SWAGED ROOF 5" OD X 123"	1	0	0	65	65

Total User Capacity: 90  
Total Weight: 5,707 lbs.

**Total Equipment Price: \$51,853**  
**Special Courtesy Discount: -(12,277)**  
**Shipping Cost: 3,212**  
**Total: \$42,788**

**Pricing By Others:**

**Removal of Existing Equipment: \$4,000**  
**240 Lineal Feet of Orange & Silt Fence: \$2,000**  
**3,000 Sq Ft of Engineered Wood Fiber @ 4" Deep: \$2,400**  
**Restoration of 1,500 Sq Ft: \$2,000**  
**Bond Requirements: \$1,500**  
**Installation of New Play Structure and 2 Swing Seats: \$15,555**  
**TOTAL BY OTHERS: \$27,455**

**PROJECT TOTAL: \$70,243**

**Special Notes:**

Prices do not include unloading, material storage, removal of excess soil from footing holes, site security, or sales tax (if applicable). Prices are based on standard colors per CURRENT YEAR BCI Burke Catalog. Custom colors, where available, would be an extra charge. **Pricing is valid for 45 days from the date of this proposal.**



# Proposal # 129-114919-1

January 22, 2019  
2019 Pricing

## ***Selected Color List***

<b><u>Color Group</u></b>	<b><u>Color</u></b>
<i>Phase 1</i>	
Accessory	Olive
Platform	Brown
Post	Charcoal
Kore Konnect	Charcoal
Rotomolded	Orange
1 Color Extruded/Flat	Orange
2 Color Extruded/Flat (outer)	Orange
2 Color Extruded/Flat (inner)	Black
Intensity/Rocky Mountain	Orange
<i>Phase 2</i>	
Contemporary Swing Fittings	Charcoal
Platform	Brown
Rotomolded	Orange
Accessory	Olive





# Proposal # 129-114919-1

January 22, 2019  
2019 Pricing

## **Konnection Swing™**

### Safety Standards & Guidelines - Reference Information

The Konnection Swing was designed to provide an intergenerational play opportunity and offer everyone the childhood joy of swinging! While researching the use of swings, two trends stood out to us - caregivers pushing infants in bucket seat swings and adults swinging with children on their lap. Both situations could be improved with the design of a swing designed to foster connection and increase safety. The Konnection Swing was developed as a direct result of this. The overall design is focused on fostering true connection in both eye contact and proximity leading to increased engagement for all users. Hands-free swinging allows the caregiver to hold, interact and play with the child as they both experience the thrill of swinging together.

The Konnection Swing is IPEMA Certified and meets or exceeds the requirements of ASTM F1487-17, which is recognized as the standard of care in the playground industry. This ASTM public playground safety standard is revised every two to three years to remain current with innovation and market trends.

The CPSC Public Playground Safety Handbook hasn't been revised since 2008 and doesn't include new product categories that have been innovated in recent years. There are a couple of points to note when deciding to purchase a multi-user swing:

- Multi-user swings are innovative and CPSC Public Playground Safety Handbook doesn't have a standard that specifically covers them.
- CPSC 5.3.8.3.1 – CPSC recommends that belt swing seats should be designed to accommodate no more than one user at any time. While the Konnection Swing is a single axis swing, it is clearly not a belt seat.
- CPSC 2.3.1 – CPSC says that swings intended for more than one user are not recommended because their greater mass, as compared to single occupancy swings, presents a risk of impact injury.
  - The ASTM safety standard, F1487, was revised in 2011 to add maximum impact requirements for swings and the Konnection Swing has been tested and is compliant with ASTM impact requirements.
  - CPSC has written a letter stating that “the swing impact test in F1487-11 is a reasonable approach to address the concerns posed by unoccupied, heavy, multiple occupancy swings.”
- CPSC has always included an exemption to both recommendations listed above for tire swings, which are multiple occupancy swings that are suspended from a single pivot and permit swinging in any direction.
- CPSC also emphasizes that their Handbook provides recommendations, not requirements. If a jurisdiction adopts the Handbook's recommendations as mandatory requirements, that jurisdiction would need to determine how the requirements should be applied in any particular instance.

# BURKE GENERATIONS WARRANTY®

## The Longest and Strongest warranty in the industry

BCI Burke Company, LLC ("Burke") warrants that all standard products are warranted to be free from defects in materials and workmanship, under normal use and service, for a period of one (1) year from the date of invoice.

### We stand behind our products.

In addition, the following products are warranted, under normal use and service from the date of invoice as follows:

- One Hundred (100) Year Limited Warranty on aluminum and steel upright posts (including Intensity®, Voltage®, Nucleus®, Little Buddies® and ELEVATE®/ACTIVATE®) against structural failure due to corrosion, deterioration or workmanship.
- One Hundred (100) Year Limited Warranty on KoreConnect® clamps against structural failure due to corrosion, deterioration or workmanship.
- One Hundred (100) Year Limited Warranty on Hardware (nuts, bolts, washers)
- One Hundred (100) Year Limited Warranty on bolt-through fastening and clamp systems (Voltage®, Intensity®, Nucleus®, Little Buddies® and ELEVATE®/ACTIVATE®).
- Twenty-five (25) Year Limited Warranty on spring assemblies and aluminum cast animals.
- Fifteen (15) Year Limited Warranty on main structure platforms and decks, metal roofs, table tops, bench tops, railings and barriers.
- Fifteen (15) Year Limited Warranty on all plastic components including StoneBorders against structural failure due to materials or workmanship.
- Ten (10) Year Limited Warranty on ShadePlay Canopies fabric, threads, and cables against degradation, cracking or material breakdown resulting from ultra-violet exposure, natural deterioration or manufacturing defects. This warranty is limited to the design loads as stated in the specifications.
- Ten (10) Year Limited Warranty on NaturePlay® Boulders and GFRC products against structural failure due to natural deterioration or workmanship. Natural wear, which may occur with any concrete product with age, is excluded from this warranty.
- Ten (10) Year Limited Warranty on Full Color Custom Signage against manufacturing defects that cause delamination or degradation of the sign. Full Color Custom Signs also carry a two (2) year warranty against premature fading of the print and graphics on the signs.
- Five (5) Year Limited Warranty on Intensity® and RopeVenture® cables and LEVEL X® flex bridge against premature wear due to natural deterioration or manufacturing defects. Determination of premature wear will be at the manufacturer's discretion.
- Five (5) Year Limited Warranty on swing seats and hangers; Kid Koaster® Trolleys and other moving parts against structural failure due to materials or workmanship.
- Five (5) Year Limited Warranty on PlayEnsemble® cables and mallets against defects in materials and workmanship.
- Three (3) Year Limited Warranty on electronic panel speakers, sound chips and circuit boards against electronic failure caused by manufacturing defects.

The warranty stated above is valid only if the equipment is erected in conformity with the layout plan and/or installation instructions furnished by BCI Burke Company, LLC using approved parts, have been maintained and inspected in accordance with BCI Burke Company, LLC instructions. Burke's liability and your exclusive remedy hereunder will be limited to repair or replacement of those parts found in Burke's reasonable judgment to be defective. Any claim made within the above stated warranty periods must be made promptly after discovery of the defect. A part is covered only for the original warranty period of the applicable part. Replacement parts carry the applicable warranty from the date of shipment of the replacement from Burke. After the expiration of the warranty period, you must pay for all parts, transportation and service charges.

Burke reserves the right to accept or reject any claim in whole or in part. Burke will not accept the return of any product without its prior written approval. Burke will assume transportation charges for shipment of the returned product if it is returned in strict compliance with Burke's written instructions.

**THE FOREGOING WARRANTIES ARE EXCLUSIVE AND IN LIEU OF ANY OTHER WARRANTY, EXPRESS OR IMPLIED, INCLUDING BUT NOT LIMITED TO ANY IMPLIED WARRANTY OF MERCHANTABILITY OR FITNESS FOR A PARTICULAR PURPOSE. IF THE FOREGOING DISCLAIMER OF ADDITIONAL WARRANTIES IS NOT GIVEN FULL FORCE AND EFFECT, ANY RESULTING ADDITIONAL WARRANTY SHALL BE LIMITED IN DURATION TO THE EXPRESS WARRANTIES AND BE OTHERWISE SUBJECT TO AND LIMITED BY THE TERMS OF BURKE'S PRODUCT WARRANTY. SOME STATES DO NOT ALLOW THE EXCLUSION OF CERTAIN IMPLIED WARRANTIES, SO THE ABOVE LIMITATION MAY NOT APPLY TO YOU.**

**Warranty Exclusions:** The above stated warranties do not cover: "cosmetic" defects, such as scratches, dents, marring, or fading; damage due to incorrect installation, vandalism, misuse, accident, wear and tear from normal use, exposure to extreme weather; immersion in salt or chlorine water, unauthorized repair or modification, abnormal use, lack of maintenance, or other cause not within Burke's control; and

**Limitation of Remedies:** Burke is not liable for consequential or incidental damages, including but not limited to labor costs or lost profits resulting from the use of or inability to use the products or from the products being incorporated in or becoming a component of any other product. If, after a reasonable number of repeated efforts, Burke is unable to repair or replace a defective or nonconforming product, Burke shall have the option to accept return of the product, or part thereof, if such does not substantially impair its value, and return the purchase price as the buyer's entire and exclusive remedy. Without limiting the generality of the foregoing, Burke will not be responsible for labor costs involved in the removal of products or the installation of replacement products. Some states do not allow the exclusion of incidental damages, so the above exclusion may not apply to you.

Contact your local Burke Representative for warranty information regarding Burke-Turf® and Burke-Tile products.

### Terms of Sale

**Pricing:** Prices published in this catalog are in USD, are approximate and do not include shipping & handling, surfacing, installation nor applicable taxes. All prices are subject to change without notice. Contact your Burke representative for current pricing. Payments are to be made in USD.

**Weights:** Weights are approximate and may vary with actual orders.

**Installation:** All equipment is shipped unassembled. For a list of factory-certified installers in your area, please contact your Burke representative.

**Specifications:** Product specifications in this catalog were correct at the time of publication. However, product improvements are ongoing at Burke, and we reserve the right to change or discontinue specifications without notice.

**Loss or Damage in Transit:** A signed bill of lading is our receipt from a carrier that our shipment to you was complete and in good condition upon arrival. Before you sign, please check the Bill of Lading carefully when the shipment arrives to make sure nothing is missing and there are no damages. Once the shipment leaves our plant, we are no longer responsible for any damage, loss or shortage.

For more information regarding the warranty, call Customer Service at 920-921-9220 or 1-800-356-2070.

01/2019

BCIBURKE.COM

**Burke**

800.266.1250



PROPOSAL: 129-114919-1 LA BUY PARK



# Village of Lake in the Hills Park & Recreation La Buy Park

Proposal # 129-114922-1  
January 22, 2019

Presented by  
Play Illinois, LLC

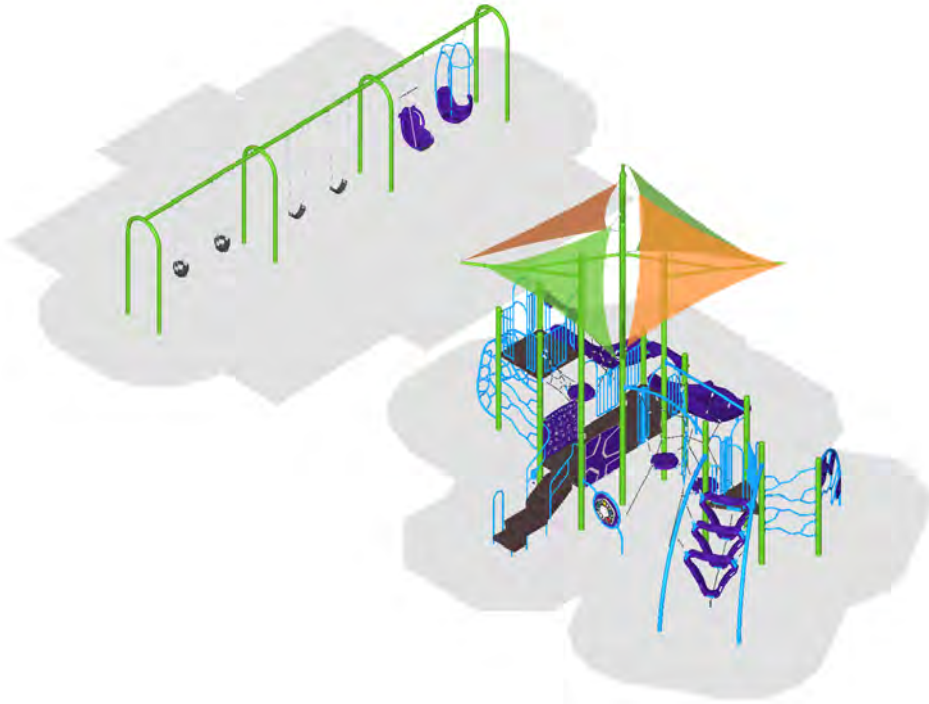

# Burke®



January 22, 2019

Jerry Marsh  
Village of Lake in the Hills Park & Recreations  
9010 Haligus Road  
Lake in the Hills, IL 60156

Dear Jerry Marsh:

Play Illinois, LLC is delighted to provide Village of Lake in the Hills Park & Recreations with this playground equipment proposal.

This design was developed with your specific needs in mind, and we look forward to discussing this project further with you to ensure your complete satisfaction. Play Illinois, LLC is confident that this proposal will satisfy Village of Lake in the Hills Park & Recreations's functional, environmental, and safety requirements -- and most importantly -- bring joy and excitement to the children and families directly benefiting from your new playground.

You have our personal commitment to support this project and your organization in every manner possible, and we look forward to continue developing a long-standing relationship with Village of Lake in the Hills Park & Recreations. We appreciate your consideration and value this opportunity to earn your business.

Sincerely,

Cheryl Parson  
Play Illinois, LLC  
4716 Roslyn Rd.  
Downers Grove, IL 60515

## **Design Summary**

Play Illinois, LLC is very pleased to present this Proposal for consideration for the La Buy Park located in Lake in the Hills. BCI Burke Company, LLC has been providing recreational playground equipment for over 90 years and has developed the right mix of world-class capabilities to meet the initial and continuing needs of Village of Lake in the Hills Park & Recreations. We believe our proposal will meet or exceed your project's requirements and will deliver the greatest value to you.

The following is a summary of some of the key elements of our Proposal:

- Project Name: La Buy Park
- Project Number: 129-114922-1
- User Capacity: 90
- Age Groups: Ages 5-12 years
- Dimensions: 76' 7" x 46' 7"
- Designer Name: Tyler Hess

Play Illinois, LLC has developed a custom playground configuration based on the requirements as they have been presented for the La Buy Park playground project. Our custom design will provide a safe and affordable playground environment that is aesthetically pleasing, full of fun for all users and uniquely satisfies your specific requirements. In addition, proposal # 129-114922-1 has been designed with a focus on safety, and is fully compliant with ASTM F1487 and CPSC playground safety standards.

We invite you to review this proposal for the La Buy Park playground project and to contact us with any questions that you may have.

Thank you in advance for giving us the opportunity to make this project a success.

INFORMATION  
MINIMUM FALL ZONE  
SURFACED WITH  
RESILIENT MATERIAL  
AREA

2256 SQ.FT.

PERIMETER

292 FT.

STRUCTURE SIZE

76' 7" x 46' 7"

STRUCTURE IS DESIGNED  
FOR CHILDREN AGES:

- 6-23 MONTH OLDS
- 2-5 YEAR OLDS
- 5-12 YEAR OLDS
- 13 + YEAR OLDS



Registered  
to ISO 9001



Registered  
to ISO 14001



To verify product certification,  
visit [www.ipema.org](http://www.ipema.org)

The play components identified  
in this plan are IPEMA  
certified. The use and layout of  
these components conform to the  
requirements of ASTM F1487.  
To verify product certification,  
visit [www.ipema.org](http://www.ipema.org)

The space requirements shown  
here are to ASTM standards.  
Requirements for other standards  
may be different.

The use and layout of play  
components identified in this plan  
conform to the CPSC guidelines.  
U.S. CPSC recommends the  
separation of age groups in  
playground layouts.

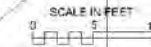
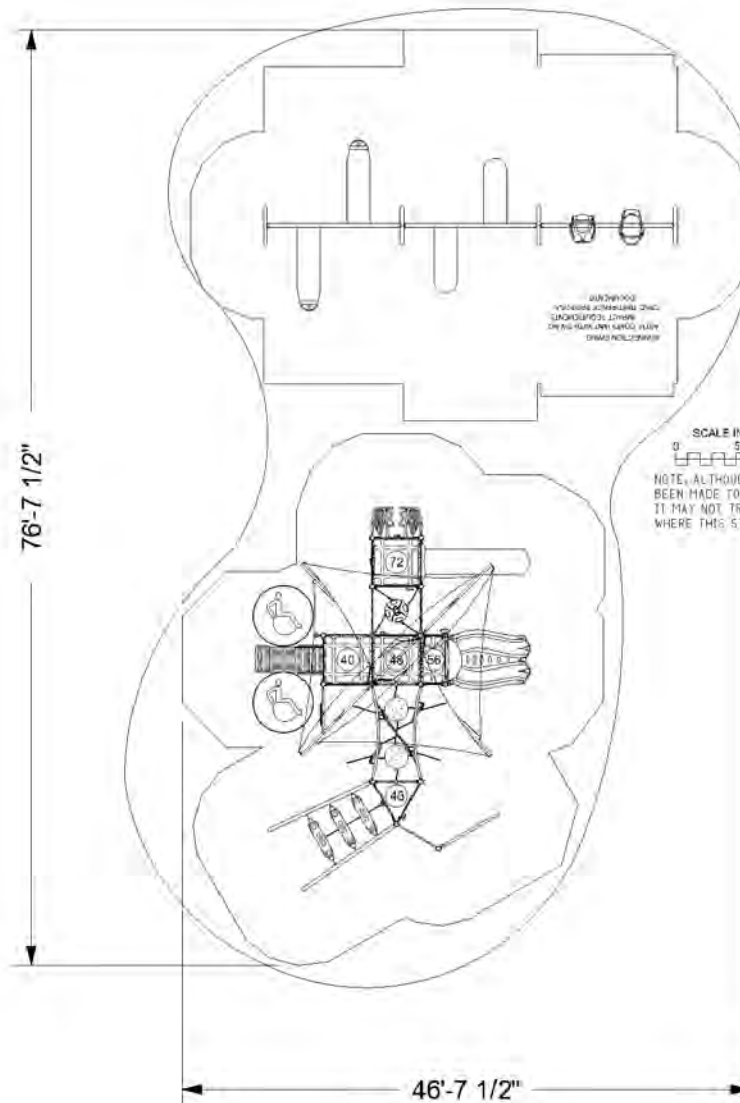

NOTE: ALTHOUGH ALL ATTEMPTS HAVE  
BEEN MADE TO PROVIDE AN ACCURATE SITE  
IT MAY NOT TRULY REPRESENT THE AREA  
WHERE THIS STRUCTURE IS TO BE PLACED.

ADA ACCESSIBILITY GUIDELINE (ADAAG CONFORMANCE)

NUMBER OF PLAY EVENTS	20		
NUMBER OF ELEVATED PLAY EVENTS:	10		
NUMBER OF ELEVATED PLAY EVENTS ACCESSIBLE BY RAMP	PROVIDED: 0	REQD: 0	
NUMBER OF ELEVATED PLAY EVENTS ACCESSIBLE BY TRANSFER SYSTEM	PROVIDED: 5	REQD: 5	
NUMBER OF ELEVATED PLAY EVENTS ACCESSIBLE BY RAMP OR TRANSFER SYSTEM:		REQD: 5	
NUMBER OF GROUND LEVEL PLAY EVENTS:	PROVIDED: 10	REQD: 3	
NUMBER OF TYPES OF GROUND LEVEL PLAY EVENTS:	PROVIDED: 5	REQD: 3	

WARNING!

ACCESSIBLE SAFETY SURFACING MATERIAL IS REQUIRED BENEATH  
AND AROUND THIS EQUIPMENT.

FOR SLIDE FALL ZONE SURFACING AREA SEE CPSC's Handbook for  
Public Playground Safety.

PLATFORM HEIGHTS ARE IN INCHES ABOVE RESILIENT MATERIAL.

**Burke**

SERIES: Basics, Intensity, Nucleus

SITE PLAN

DRAWN BY: Tyler Hess

La Buy Park

35 Hilltop Drive

Lake in the Hills, IL 60156

Play Illinois, LLC

129-114922-1

January 22, 2019

ITEM	COMP.	DESCRIPTION
1	270-0001	OFFSET ENCLOSURE
2	270-0050	8" CLOSURE PLATE
3	270-0112	UNITARY ENCLOSURE
4	270-0129	TRIANGLE PLATFORM
5	270-0130	SQUARE PLATFORM
6	270-0290	HALF PLATFORM
7	370-0719	TRANSFER STATION, HANDRAIL
8	370-0810	POWER PEAK W/ PANELS
9	370-0838	TRIGON ARCH CLIMBER
10	370-0855	MERGE CLIMBER
11	370-0865	TREE BRANCH CLIMBER 72"
12	370-0868	TREE BRANCH CLIMBER-4
13	370-1619	TAKTIKS TRESTLE CLIMBER
14	370-1622	TAKTIKS TRAIL TOWER
15	370-1623	CRUNCH BAR STATION
16	470-0670	ARA SQUARE SHADE CANOPY
17	470-0753	VELO SLIDE, 64"-72"
18	470-0755	LUGE SLIDE, 48"-56"
19	550-0100	TOT SEAT, 7' & 8' PAIR, STD CHA
20	550-0112	BELT SEAT, 8' PAIR, STD CHAIN
21	550-0158	3 1/2" OD ARCH SWING
22	550-0159	3 1/2" OD ARCH SWING ADD-ON
23	550-0171	FREEDOM SWING SEAT, 8' BEAM
24	550-0191	KONNECTION SWING
25	570-0848	SIGNING 2-SIDED PLAY PANEL
26	570-0861	MEMORY RING PANEL
27	570-2624	HALF PIPE WALL
28	570-2642	CRAZY MAZE PANEL
29	670-0156	POST MOUNTED BELL

KONNECTION SWING  
 ASTM COMPLIANT WITH SWING  
 IMPACT REQUIREMENTS  
 OPCS: REFERENCE PROPOSAL  
 DOCUMENTS

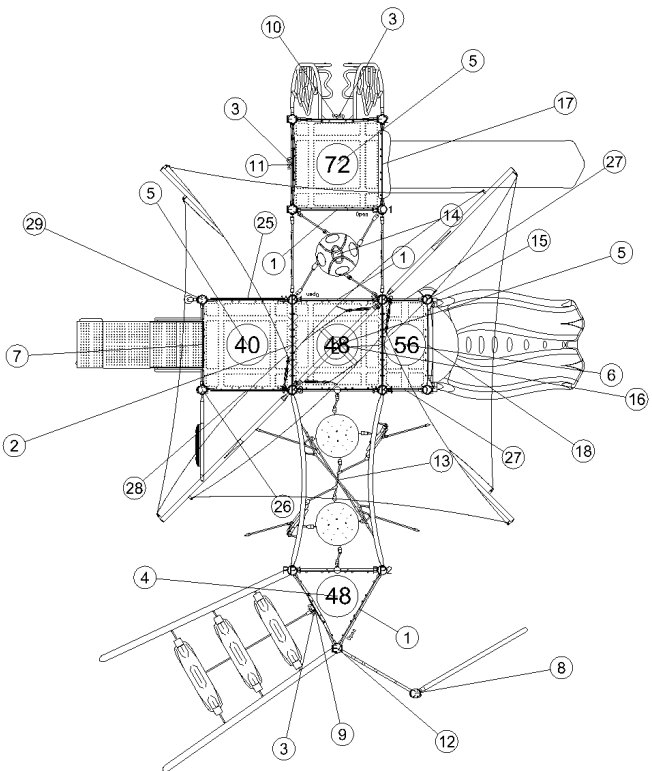
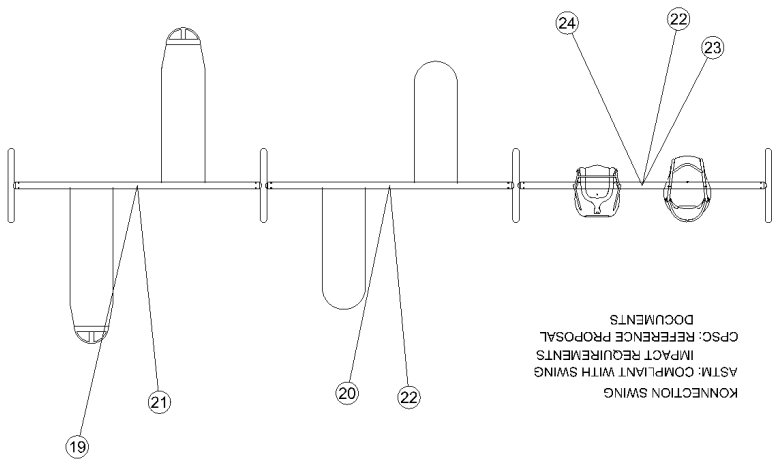

**Burke**

SERIES: Basics, Intensity, Nucleus  
 COMPONENT PLAN  
 DRAWN BY: Tyler Hess

La Buy Park  
 35 Hilltop Drive  
 Lake in the Hills, IL 60156

January 22, 2019  
 Play Illinois, LLC  
 129-114922-1

BCI Burke Company, LLC PO Box 549 Fond du Lac, Wisconsin 54936-0549 Telephone 920-921-9220





The protective surfacing for this design must accomodate the critical fall height.

**Burke**

SERIES: Basics, Intensity, Nucleus  
 ELEVATION PLAN  
 DRAWN BY: Tyler Hess

La Buy Park  
 35 Hilltop Drive  
 Lake in the Hills, IL 60156

January 22, 2019  
 Play Illinois, LLC  
 129-114922-1

BCI Burke Company, LLC PO Box 549 Fond du Lac, Wisconsin 54936-0549 Telephone 920-921-9220

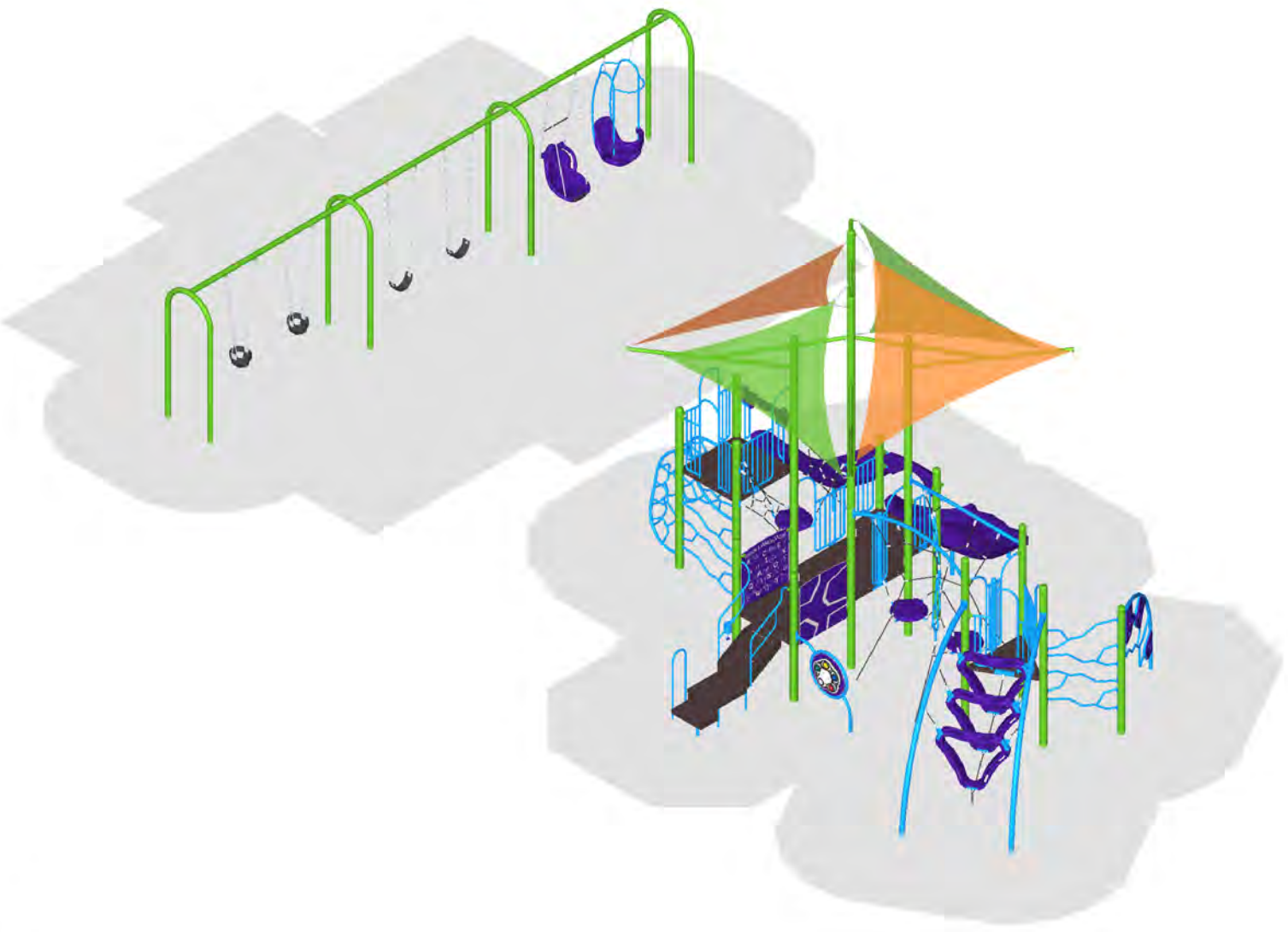

**Burke**

SERIES: Basics, Intensity, Nucleus  
ISOMETRIC PLAN  
DRAWN BY: Tyler Hess

La Buy Park  
35 Hilltop Drive  
Lake in the Hills, IL 60156

BCI Burke Company, LLC PO Box 549 Fond du Lac, Wisconsin 54936-0549 Telephone 920-921-9220

January 22, 2019

Play Illinois, LLC  
129-114922-1



# Proposal # 129-114922-1

January 22, 2019  
2019 Pricing

**Proposal Prepared for:**  
Jerry Marsh  
Village of Lake in the Hills  
9010 Haligus Road  
Lake in the Hills, IL 60156

**Project Location:**  
La Buy Park  
35 Hilltop Drive  
Lake in the Hills, IL 60156

**Proposal Prepared by:**  
Play Illinois, LLC  
4716 Roslyn Rd.  
Downers Grove, IL 60515

Cheryl Parson  
Phone: 630-200-8759  
[cparson@playil.com](mailto:cparson@playil.com)

Component No.	Description	Qty.	User Cap.	Ext. User Cap.	Weight	Ext. Weight
<b>Burke Basics (<u>Swing Seats &amp; Chains Only</u>)</b>						
550-0171	FREEDOM SWING SEAT, 8' BEAM, ...	1	1	1	38	38
550-0191	KONNECTION SWING	1	2	2	64	64
<b>Intensity</b>						
370-0868	TREE BRANCH CLIMBER-4	1	4	4	33	33
570-0861	MEMORY RING PANEL	1	2	2	77	77
<b>Nucleus</b>						
270-0001	OFFSET ENCLOSURE	3	0	0	30	90
270-0050	8" CLOSURE PLATE	2	0	0	10	20
270-0112	UNITARY ENCLOSURE	3	0	0	34	102
270-0129	TRIANGLE PLATFORM	1	2	2	48	48
270-0130	SQUARE PLATFORM	3	6	18	106	318
270-0290	HALF PLATFORM	1	3	3	57	57
370-0719	TRANSFER STATION, HANDRAIL 40"	1	5	5	199	199
370-0810	POWER PEAK W/ PANELS	1	8	8	87	87
370-0838	TRIGON ARCH CLIMBER	1	9	9	225	225
370-0855	MERGE CLIMBER	1	3	3	93	93
370-0865	TREE BRANCH CLIMBER 72"	1	4	4	33	33
370-1619	TAKTIKS TRESTLE CLIMBER	1	8	8	247	247
370-1622	TAKTIKS TRAIL TOWER	1	5	5	52	52
370-1623	CRUNCH BAR STATION	1	1	1	4	4
470-0670	ARA SQUARE SHADE CANOPY	1	0	0	383	383
470-0753	VELO SLIDE, 64"-72"	1	2	2	146	146
470-0755	LUGE SLIDE, 48"-56"	1	4	4	198	198
570-0848	SIGNING 2-SIDED PLAY PANEL	1	2	2	44	44
570-2624	HALF PIPE WALL	2	0	0	20	40
570-2642	CRAZY MAZE PANEL	1	2	2	44	44
600-0104	NPPS SUPERVISION SAFETY KIT	1	0	0	3	3
670-0099	INSTALLATION KIT, INTENSITY	1	0	0	2	2
670-0103	MAINTENANCE KIT, INTENSITY	1	0	0	0	0
670-0156	POST MOUNTED BELL	1	1	1	5	5
670-0163	POST, SWAGED ROOF 5" OD X 220"	4	0	0	115	460
670-0165	POST ASSEMBLY 5" OD X 123"	3	0	0	66	198
670-0166	POST ASSEMBLY 5" OD X 139"	2	0	0	74	148
670-0167	POST ASSEMBLY 5" OD X 147"	4	0	0	78	312



# Proposal # 129-114922-1

January 22, 2019  
2019 Pricing

670-0168 POST ASSEMBLY 5" OD X 158"	2	0	0	84	168
670-0169 POST ASSEMBLY 5" OD X 171"	1	0	0	91	91

Total User Capacity: 90  
Total Weight: 4,655 lbs.

**Total Equipment Price: \$51,261**  
**Special Courtesy Discount: -(12,130)**  
**Shipping Cost: 3,187**  
**Total: \$42,318**

**Pricing By Others:**

**Removal of Existing Equipment: \$4,000**  
**240 Lineal Feet of Orange & Silt Fence: \$2,000**  
**3,000 Sq Ft of Engineered Wood Fiber @ 4" Deep: \$2,400**  
**Restoration of 1,500 Sq Ft: \$2,000**  
**Bond Requirements: \$1,500**  
**Installation of New Play Structure and 2 Swing Seats: \$15,378**  
**TOTAL BY OTHERS: \$27,278**

**PROJECT TOTAL: \$69,596**

**Special Notes:**

Prices do not include unloading, material storage, removal of excess soil from footing holes, site security, or sales tax (if applicable). Prices are based on standard colors per CURRENT YEAR BCI Burke Catalog. Custom colors, where available, would be an extra charge. **Pricing is valid for 45 days from the date of this proposal.**



# Proposal # 129-114922-1

January 22, 2019  
2019 Pricing

Information is relative to the Jan 22 2019 4:35AM database.

**Special Notes:**

Prices do not include freight, unloading, material storage, site excavation/preparation, removal of existing equipment, removal of excess soil from footing holes, site security, safety surfacing, installation, or sales tax (if applicable). Prices are based on standard colors per CURRENT YEAR BCI Burke Catalog. Custom colors, where available, would be an extra charge. **Pricing is valid for 45 days from the date of this proposal.**



# Proposal # 129-114922-1

January 22, 2019  
2019 Pricing

## ***Selected Color List***

<b><u>Color Group</u></b>	<b><u>Color</u></b>
<i>Phase 1</i>	
Platform	Brown
Accessory	Sky
Rotomolded	Purple
Kore Konnect	Lime
Post	Lime
2 Color Extruded/Flat (outer)	Purple
2 Color Extruded/Flat (inner)	Gray
1 Color Extruded/Flat	Purple
<i>Phase 2</i>	
Contemporary Swing Fittings	Lime
Platform	Brown
Rotomolded	Purple
Accessory	Sky



# Proposal # 129-114922-1

January 22, 2019  
2019 Pricing

## **Konnection Swing™**

### Safety Standards & Guidelines - Reference Information

The Konnection Swing was designed to provide an intergenerational play opportunity and offer everyone the childhood joy of swinging! While researching the use of swings, two trends stood out to us - caregivers pushing infants in bucket seat swings and adults swinging with children on their lap. Both situations could be improved with the design of a swing designed to foster connection and increase safety. The Konnection Swing was developed as a direct result of this. The overall design is focused on fostering true connection in both eye contact and proximity leading to increased engagement for all users. Hands-free swinging allows the caregiver to hold, interact and play with the child as they both experience the thrill of swinging together.

The Konnection Swing is IPEMA Certified and meets or exceeds the requirements of ASTM F1487-17, which is recognized as the standard of care in the playground industry. This ASTM public playground safety standard is revised every two to three years to remain current with innovation and market trends.

The CPSC Public Playground Safety Handbook hasn't been revised since 2008 and doesn't include new product categories that have been innovated in recent years. There are a couple of points to note when deciding to purchase a multi-user swing:

- Multi-user swings are innovative and CPSC Public Playground Safety Handbook doesn't have a standard that specifically covers them.
- CPSC 5.3.8.3.1 – CPSC recommends that belt swing seats should be designed to accommodate no more than one user at any time. While the Konnection Swing is a single axis swing, it is clearly not a belt seat.
- CPSC 2.3.1 – CPSC says that swings intended for more than one user are not recommended because their greater mass, as compared to single occupancy swings, presents a risk of impact injury.
  - The ASTM safety standard, F1487, was revised in 2011 to add maximum impact requirements for swings and the Konnection Swing has been tested and is compliant with ASTM impact requirements.
  - CPSC has written a letter stating that “the swing impact test in F1487-11 is a reasonable approach to address the concerns posed by unoccupied, heavy, multiple occupancy swings.”
- CPSC has always included an exemption to both recommendations listed above for tire swings, which are multiple occupancy swings that are suspended from a single pivot and permit swinging in any direction.
- CPSC also emphasizes that their Handbook provides recommendations, not requirements. If a jurisdiction adopts the Handbook's recommendations as mandatory requirements, that jurisdiction would need to determine how the requirements should be applied in any particular instance.

# BURKE GENERATIONS WARRANTY®

## The Longest and Strongest warranty in the industry

BCI Burke Company, LLC ("Burke") warrants that all standard products are warranted to be free from defects in materials and workmanship, under normal use and service, for a period of one (1) year from the date of invoice.

### We stand behind our products.

In addition, the following products are warranted, under normal use and service from the date of invoice as follows:

- One Hundred (100) Year Limited Warranty on aluminum and steel upright posts (including Intensity®, Voltage®, Nucleus®, Little Buddies® and ELEVATE®/ACTIVATE®) against structural failure due to corrosion, deterioration or workmanship.
- One Hundred (100) Year Limited Warranty on KoreConnect® clamps against structural failure due to corrosion, deterioration or workmanship.
- One Hundred (100) Year Limited Warranty on Hardware (nuts, bolts, washers)
- One Hundred (100) Year Limited Warranty on bolt-through fastening and clamp systems (Voltage®, Intensity®, Nucleus®, Little Buddies® and ELEVATE®/ACTIVATE®).
- Twenty-five (25) Year Limited Warranty on spring assemblies and aluminum cast animals.
- Fifteen (15) Year Limited Warranty on main structure platforms and decks, metal roofs, table tops, bench tops, railings and barriers.
- Fifteen (15) Year Limited Warranty on all plastic components including StoneBorders against structural failure due to materials or workmanship.
- Ten (10) Year Limited Warranty on ShadePlay Canopies fabric, threads, and cables against degradation, cracking or material breakdown resulting from ultra-violet exposure, natural deterioration or manufacturing defects. This warranty is limited to the design loads as stated in the specifications.
- Ten (10) Year Limited Warranty on NaturePlay® Boulders and GFRC products against structural failure due to natural deterioration or workmanship. Natural wear, which may occur with any concrete product with age, is excluded from this warranty.
- Ten (10) Year Limited Warranty on Full Color Custom Signage against manufacturing defects that cause delamination or degradation of the sign. Full Color Custom Signs also carry a two (2) year warranty against premature fading of the print and graphics on the signs.
- Five (5) Year Limited Warranty on Intensity® and RopeVenture® cables and LEVEL X® flex bridge against premature wear due to natural deterioration or manufacturing defects. Determination of premature wear will be at the manufacturer's discretion.
- Five (5) Year Limited Warranty on swing seats and hangers; Kid Koaster® Trolleys and other moving parts against structural failure due to materials or workmanship.
- Five (5) Year Limited Warranty on PlayEnsemble® cables and mallets against defects in materials and workmanship.
- Three (3) Year Limited Warranty on electronic panel speakers, sound chips and circuit boards against electronic failure caused by manufacturing defects.

The warranty stated above is valid only if the equipment is erected in conformity with the layout plan and/or installation instructions furnished by BCI Burke Company, LLC using approved parts, have been maintained and inspected in accordance with BCI Burke Company, LLC instructions. Burke's liability and your exclusive remedy hereunder will be limited to repair or replacement of those parts found in Burke's reasonable judgment to be defective. Any claim made within the above stated warranty periods must be made promptly after discovery of the defect. A part is covered only for the original warranty period of the applicable part. Replacement parts carry the applicable warranty from the date of shipment of the replacement from Burke. After the expiration of the warranty period, you must pay for all parts, transportation and service charges.

Burke reserves the right to accept or reject any claim in whole or in part. Burke will not accept the return of any product without its prior written approval. Burke will assume transportation charges for shipment of the returned product if it is returned in strict compliance with Burke's written instructions.

**THE FOREGOING WARRANTIES ARE EXCLUSIVE AND IN LIEU OF ANY OTHER WARRANTY, EXPRESS OR IMPLIED, INCLUDING BUT NOT LIMITED TO ANY IMPLIED WARRANTY OF MERCHANTABILITY OR FITNESS FOR A PARTICULAR PURPOSE. IF THE FOREGOING DISCLAIMER OF ADDITIONAL WARRANTIES IS NOT GIVEN FULL FORCE AND EFFECT, ANY RESULTING ADDITIONAL WARRANTY SHALL BE LIMITED IN DURATION TO THE EXPRESS WARRANTIES AND BE OTHERWISE SUBJECT TO AND LIMITED BY THE TERMS OF BURKE'S PRODUCT WARRANTY. SOME STATES DO NOT ALLOW THE EXCLUSION OF CERTAIN IMPLIED WARRANTIES, SO THE ABOVE LIMITATION MAY NOT APPLY TO YOU.**

**Warranty Exclusions:** The above stated warranties do not cover: "cosmetic" defects, such as scratches, dents, marring, or fading; damage due to incorrect installation, vandalism, misuse, accident, wear and tear from normal use, exposure to extreme weather; immersion in salt or chlorine water, unauthorized repair or modification, abnormal use, lack of maintenance, or other cause not within Burke's control; and

**Limitation of Remedies:** Burke is not liable for consequential or incidental damages, including but not limited to labor costs or lost profits resulting from the use of or inability to use the products or from the products being incorporated in or becoming a component of any other product. If, after a reasonable number of repeated efforts, Burke is unable to repair or replace a defective or nonconforming product, Burke shall have the option to accept return of the product, or part thereof, if such does not substantially impair its value, and return the purchase price as the buyer's entire and exclusive remedy. Without limiting the generality of the foregoing, Burke will not be responsible for labor costs involved in the removal of products or the installation of replacement products. Some states do not allow the exclusion of incidental damages, so the above exclusion may not apply to you.

Contact your local Burke Representative for warranty information regarding Burke-Turf® and Burke-Tile products.

### Terms of Sale

**Pricing:** Prices published in this catalog are in USD, are approximate and do not include shipping & handling, surfacing, installation nor applicable taxes. All prices are subject to change without notice. Contact your Burke representative for current pricing. Payments are to be made in USD.

**Weights:** Weights are approximate and may vary with actual orders.

**Installation:** All equipment is shipped unassembled. For a list of factory-certified installers in your area, please contact your Burke representative.

**Specifications:** Product specifications in this catalog were correct at the time of publication. However, product improvements are ongoing at Burke, and we reserve the right to change or discontinue specifications without notice.

**Loss or Damage in Transit:** A signed bill of lading is our receipt from a carrier that our shipment to you was complete and in good condition upon arrival. Before you sign, please check the Bill of Lading carefully when the shipment arrives to make sure nothing is missing and there are no damages. Once the shipment leaves our plant, we are no longer responsible for any damage, loss or shortage.

For more information regarding the warranty, call Customer Service at 920-921-9220 or 1-800-356-2070.

01/2019

BCIBURKE.COM

**Burke**

800.266.1250





PROPOSAL: 129-114922-1

LA BUY PARK





## LaBuy Park Playground Lake in the Hills, IL

Design • Build • PLAY!



[www.cunninghamrec.com](http://www.cunninghamrec.com)

Site shown in rendering is an interpretation and may not reflect exact site conditions. 800.438.2780



January 31, 2019

Box 2121  
 La Grange, IL 60525  
 708-579-9055  
 708-579-0109 (fax)  
 1-800-526-6197

LaBuy Park  
 LAKE IN THE HILLS, IL  
 PLAYBOOSTER & SMART PLAY SYSTEM

<u>QTY.</u>	<u>NO.</u>	<u>DESCRIPTION</u>	<u>PRICE</u>
<b>2-5 Year Olds Structure - Smart Play System</b>			
1	197057C	Motion w/Play Table DB includes: Bead Panel Bongo Panel Curved Poly Slide Inclined Tunnel Leaf Shape and Fit Panel Leaf Trail Panel Marbles Panel Numbers Climber Play Table with seats Race Car/Roller Track Ring-a-Bell Panel Shape-and-Fit Table Spelling Panel Steering Wheel Steppers Wiggle Ladder	
1	182503A	Welcome Sign (LSI Provided) Ages 2-5 years Direct Bury	

Also:

1	228215A	Rhapsody Goblet Drum Junior DB	
1	228217A	Rhapsody Kettle Drum Junior DB	
1	228218A	Rhapsody Kundu Drum Junior DB	

**5-12 Year Olds Structure - Playbooster System**

1	184490C	Swiggle Stix Bridge w/o Deck Connections DB	
1	164092B	Bongo Panel Ground Level	
1	193174A	Sol Spinner DB <sup>1</sup>	
1	111362A	Talk Tube 40' Tubing Kit PB	
2	111363A	Talk Tube At Grade Mounted DB Only	
1	193170A	LolliLadder w/2 E-Pods	

1	111404F	108"Alum Post DB
2	111404O	132"Steel Post DB 42" BURY
1	154883C	233"Steel Post (60" Bury) For CoolTopper Single Post Pyramid Roof
1	154883C	233"Steel Post (60" Bury) For CoolTopper Single Post Pyramid Roof
1	111404J	76"Alum Post DB
1	111404I	84"Alum Post DB
2	154884A	CoolToppers Single Post Pyramid Roof DB Only <sup>1</sup>
1	183176A	Rush Slide DB Only
1	182503C	Welcome Sign (LSI Provided) Ages 5-12 years Direct Bury

**Site Furnishings**

2	185915A	Arches Bench DB
1	185653A	Arches Bike Rack - Triple DB
1	141684D	Tendertuff Picnic Table 92"Table 92"Seat Permanent

**ALL OF THE ABOVE FOR A TOTAL DELIVERED PRICE OF \$48,706**

**Work By Contractor (GREEN-UP)**

**\$ 26,000**

Work to include: Performance Bond, Labor & Material Bond, Receive and unload equipment on quote LIH19ECH1-EL, Removal and disposal of existing structure, Remove and dispose of existing EWF, Supply and spread 100 CuYds of new EWF at 12" depth.

**Project Total as Listed Above**

**\$ 74,706**

EXISTING SWING SET TO REMAIN

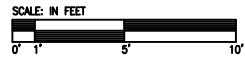
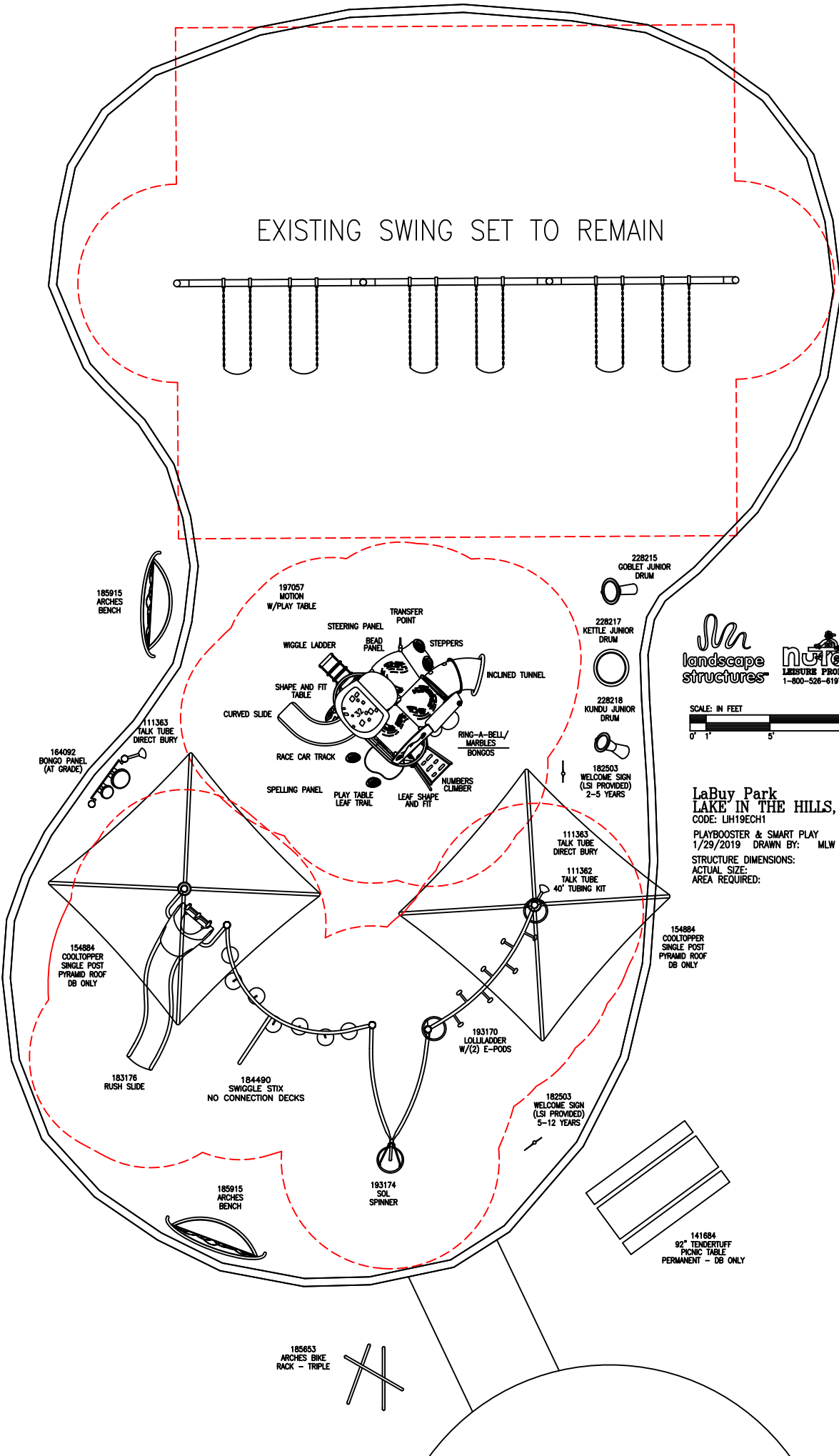

LaBuy Park  
LAKE IN THE HILLS, IL  
CODE: LH19ECH1  
PLAYBOOSTER & SMART PLAY  
1/29/2019 DRAWN BY: MLW  
STRUCTURE DIMENSIONS:  
ACTUAL SIZE:  
AREA REQUIRED:

# LaBuy Park

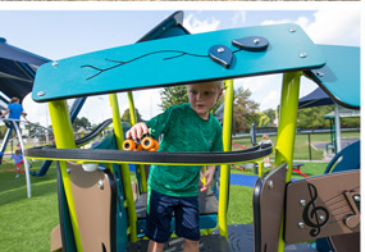

*LS*  
landscape  
structures  
PLAYLSI.COM

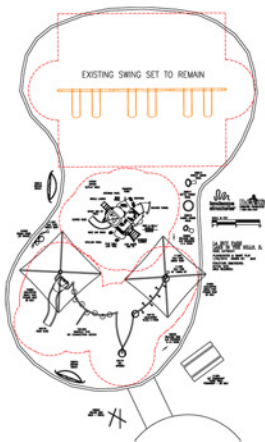

**nJOYS**  
Leisure Products  
(800) 526-6197

**General Notes:**

**Age Group**

2-5yrs  5-12 yrs  2-12yrs  13+ yrs

1. The Americans with Disabilities Act (ADA) may require that you make your park and/or playground accessible when viewed in its entirety. Please consult your legal counsel to determine if the ADA applies to you.
2. For playground equipment to be considered accessible, accessible surfacing must be utilized in applicable areas.
3. Although a particular playground design may not meet the proposed Access Board Regulations in regards to the appropriate number of ground level events, the actual playground may be in compliance when considering existing play components.
4. All deck heights are measured from top of ground cover.
5. Fall absorbing ground cover is required under and around all play equipment.
6. The minimum recommended fall zone around the entire playstructure is shown. This zone is to be free of all tripping or collision hazards (i.e. roots, rocks, border material, etc.).
7. All post lengths are identified by text showing the post lengths, i.e. 96 represents a 96 inch post.
8. Not all equipment may be appropriate for all children. Supervision is required.

AGE GROUP: 2-12  
 ELEVATED PLAY ACTIVITIES - TOTAL: 8  
 ELEVATED PLAY ACTIVITIES ACCESSIBLE BY TRANSFER: 4 REQ'D 4  
 ELEVATED PLAY ACTIVITIES ACCESSIBLE BY RAMP: 0 REQ'D 0  
 GROUND LEVEL ACTIVITY TYPE: 2 REQ'D 3  
 GROUND LEVEL QUANTITY: 4 REQ'D 3



**LaBuy Park Nu Edge  
 Lake in the Hills, IL**

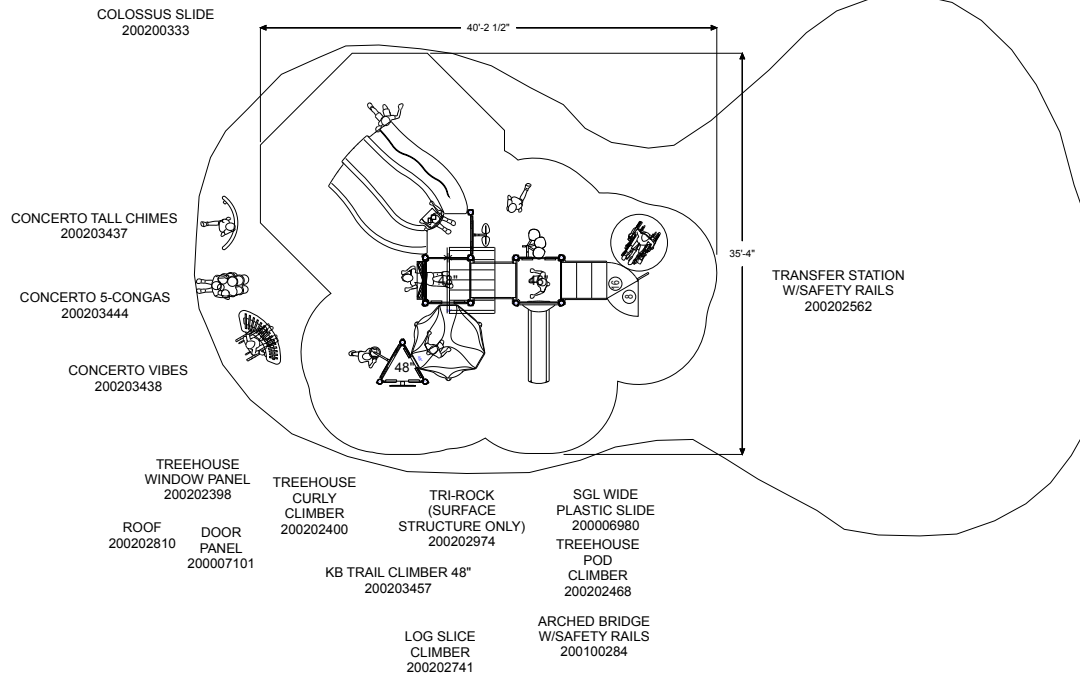

**Project:**  
 LaBuy Park Nu Edge  
 Lake in the Hills, IL  
**LTCPS rep:**  
 Lani Chaplik  
 PARKCREATION, INC.  
 (847) 419-7744

**Ground Space:** 38'-6" x 25'-6"  
**Protective Area:** 40'-6" x 35'-6"

**Drawn by:** Lani Chaplik  
**Date:** 1/30/2019  
**DWG Name:** R0309\_43494408783

**LTCPS - Farmington**  
 878 East Highway 60  
 Monett, Missouri 65708  
**Voice:** 1-800-325-8828  
**Fax:** 417-354-2273

**Playground Layout  
 Compliance:**

- ASTM F1487 - Playground Equipment for Public Use.
- CPSC Handbook for Public Playground Safety

This playground design meets the final Access Board Regulations.



The play components identified in this plan are IPEMA certified. The use and layout of these components conform to the requirements of ASTM F1487.

LEED points for this structure  
 1

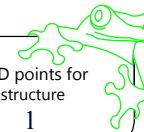

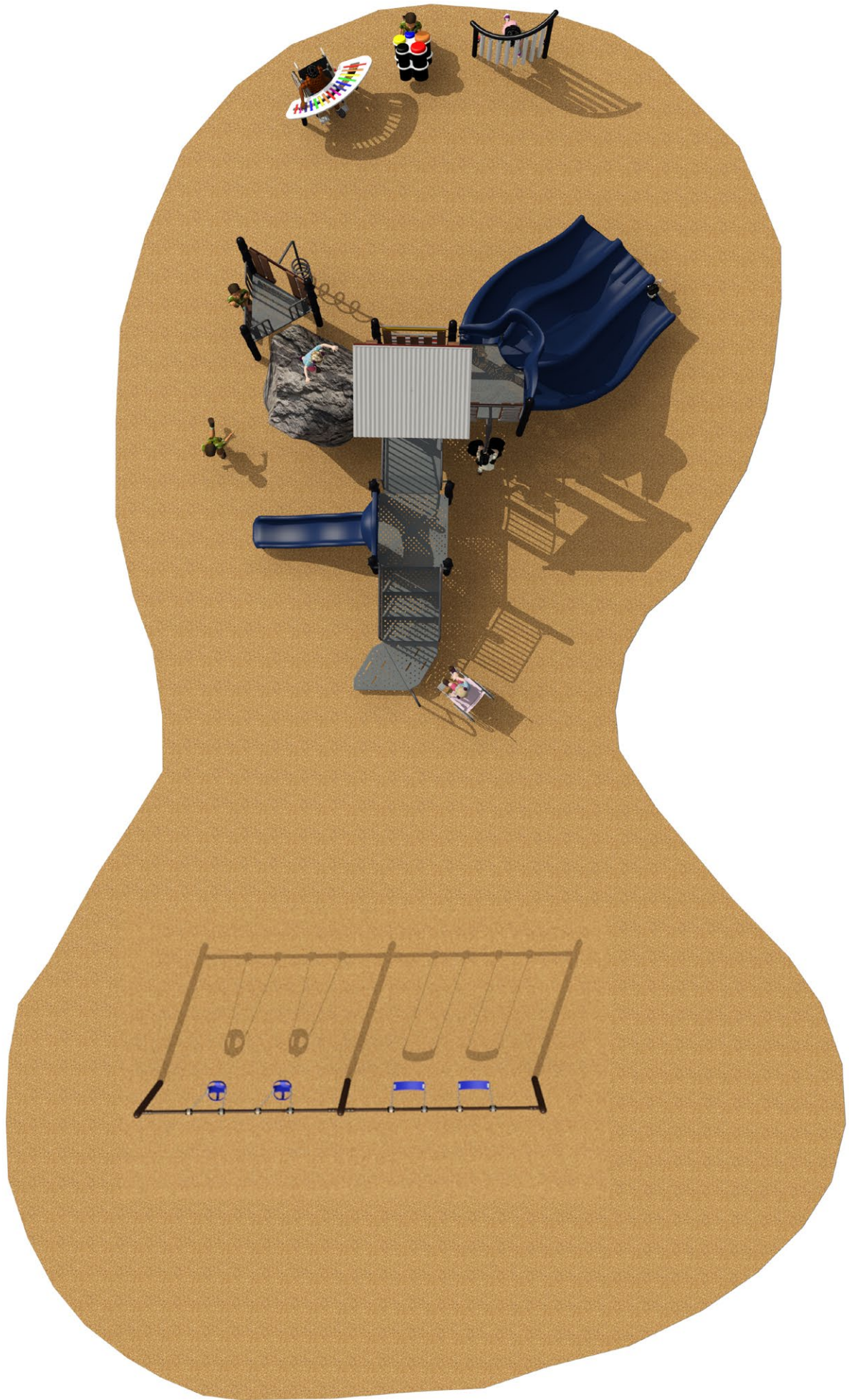







**General Notes:**

**Age Group**

- 2-5yrs    5-12 yrs    12-17yrs    18+ yrs

- The Americans with Disabilities Act (ADA) may require that you make your park and/or playground accessible when viewed in its entirety. Please consult your local code to determine if the ADA applies to you.
- For playground equipment to be considered accessible, accessible surfacing must be utilized in applicable areas.
- Although a particular playground design may not meet the proposed Access Board Regulations in regards to the appropriate number of ground level events, the actual playground may be in compliance when considering existing play components.
- All deck heights are measured from top of ground cover.
- Fall absorbing ground cover is required under and around all play equipment.
- The minimum recommended fall zone around the entire play structure is shown. This zone is to be free of all tripping or collision hazards (i.e. roots, rocks, border material, etc.).
- All post lengths are identified by text showing the post lengths, i.e. 96 represents a 96 inch post.
- Not all equipment may be appropriate for all child supervision is required.

43'-11"

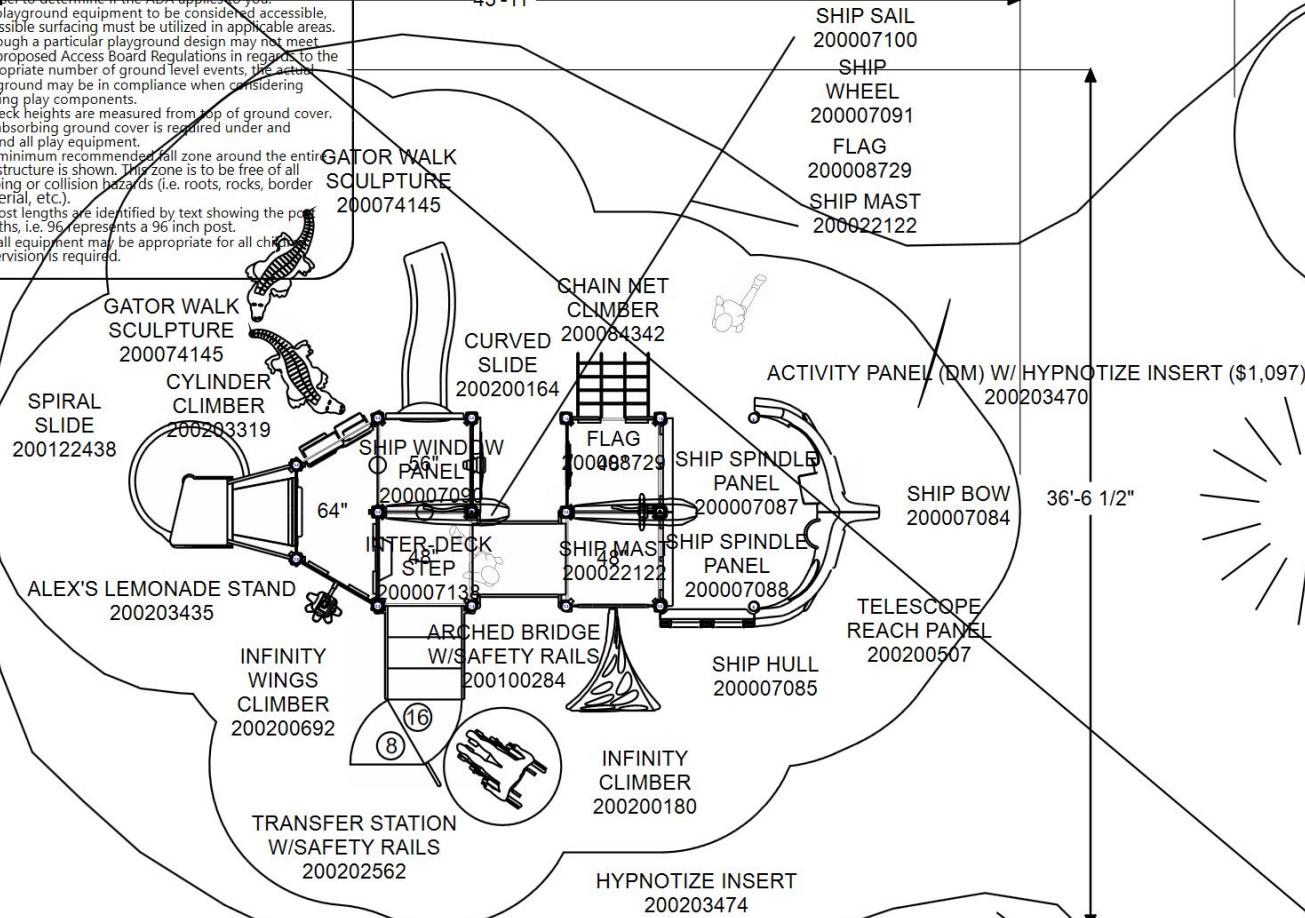

**BUBBLES THE WHALE**  
200200450



14'-8"

AGE GROUP: 2-12	ELEVATED PLAY ACTIVITIES - TOTAL: 0	ELEVATED PLAY ACTIVITIES ACCESSIBLE BY TRANSFER: 0	REQ'D 0
	ELEVATED PLAY ACTIVITIES ACCESSIBLE BY RAMP: 0	REQ'D 0	
	GROUND LEVEL ACTIVITY TYPE: 2	REQ'D 0	
	GROUND LEVEL QUANTITY: 3	REQ'D 0	

AGE GROUP: 5-12	ELEVATED PLAY ACTIVITIES - TOTAL: 8	ELEVATED PLAY ACTIVITIES ACCESSIBLE BY TRANSFER: 0	REQ'D 4
	ELEVATED PLAY ACTIVITIES ACCESSIBLE BY RAMP: 0	REQ'D 0	
	GROUND LEVEL ACTIVITY TYPE: 3	REQ'D 3	
	GROUND LEVEL QUANTITY: 3	REQ'D 3	

**Project:**  
 Lake in The Hills, IL  
 LTCPS rep:  
 Parker Simonaitis  
 PARKREATION, INC.  
 (847) 419-7744

**Ground Space:** 57'-0" x 29'-6"  
**Protective Area:** 69'-0" x 41'-6"

**Drawn by:** Lani Chaplik  
**Date:** 1/30/2019  
**DWG Name:** R0309\_43483725436

LTCPS - Farmington  
 878 East Highway 60  
 Monett, Missouri 65708  
 Voice: 1-800-325-8828  
 Fax: 417-354-2273

**Playground Layout Compliance:**

- ASTM F1487 - Playground Equipment for Public Use.
- CPSC Handbook for Public Playground Safety

This playground design meets the final Access Board Regulations.



The play components identified in this plan are IPEMA certified. The use and layout of these components conform to the requirements of ASTM F1487.

LEED points for this structure

1

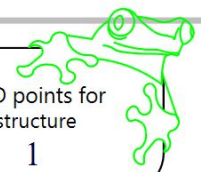

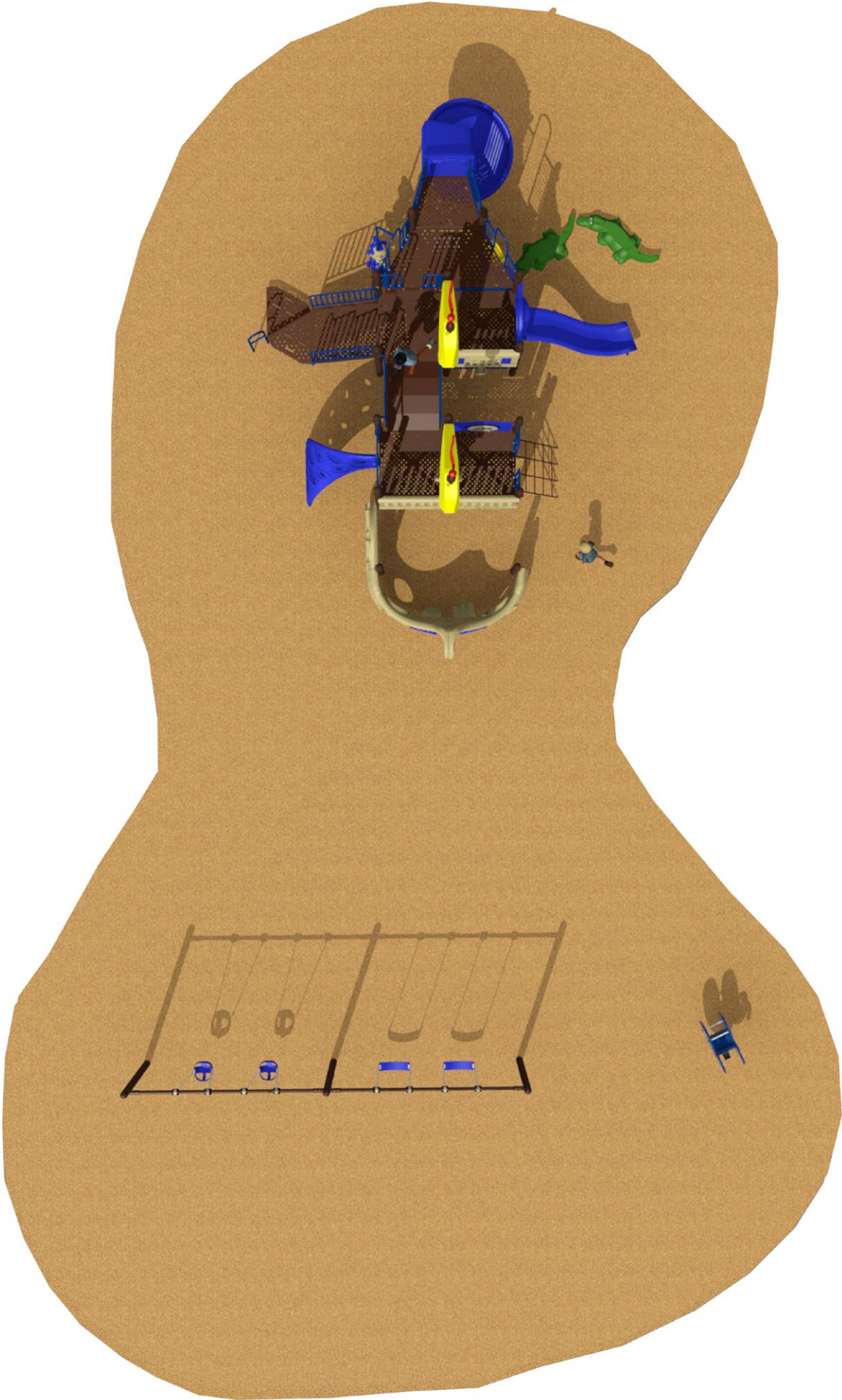





# LaBuy Park 2-12 Playground

Lake in the Hills, IL

2019



**FOR KIDS  
AGES  
2-12  
YEARS**

## Park Amenities

- Big Kahuna Climber
- Concerto Chimes and Vibes
- Alex's Lemonade Stand
- Six Swing Bay (3 belt seats, 2 bucket seats, 1 inclusive seat)
- Wavy Wedge Wall Walker
- Bongo Pods Deck to Ground Climber





**Village of Lake in the Hills  
Community Services Department  
Parks and Recreation Division  
Monthly Report – February 7, 2019**

***Dates of Interest:***                      ***Saturday, February 9 – Daddy Daughter Day and Night***  
***Monday, February 18 – Teen Job Fair***

***Parks Project Status –***

The ice rink at Sunset Park was opened to the public on January 25. Details on closures are located on the Village's website.

The LaBuy Playground Request for Simplified Proposal ended on January 31. Vendors are invited to attend a February 7 resident focus group on February 7 at 6 p.m. to assist in selection of three vendors to submit a final proposal.

Plote Field lighting improvements and scoreboard installation will take place mid-March as the weather becomes more conducive to truck traffic.

The Turtle Island project is still in consideration for the OSLAD grant. We expect to receive a response within the next month.

***Recreation Project Status –***

Preschool Academy returning family registration began on Friday, February 1. So far twelve students have registered and many calls and messages are being received. New students can register starting February 15.

Preschool Academy classes and the Beyond the Bell after school program were closed on Monday, January 8 and Wednesday January 30 through Friday, February 1 due to inclement weather. Participants are notified by email of program cancellations. All cancellations were also posted on Facebook.

230 Bark Park memberships have already been purchased for 2019.

The Ice Fishing Tournament was held on Saturday, February 2. Approximately 60 participants attended and enjoyed their time fishing. Snacks were provided and all participants were put into a drawing for door prizes. Trophies were given to the angler catching the biggest, smallest, and most fish.

Staff is beginning to plan for changes to the former parks and Recreation office space that will be transformed into two preschool classrooms for the 2019-2020 school year.

We are currently interviewing candidates for the open Recreation Coordinator position. We hope to complete the process and fill the position by mid-February.





# INFORMATIONAL MEMORANDUM

---

**MEETING DATE:** February 7, 2019  
**DEPARTMENT:** Community Services  
**SUBJECT:** Summer Program Survey 2019

## EXECUTIVE SUMMARY

---

Staff developed a survey to gain resident feedback to guide summer program planning. The survey was created in survey monkey and the link was posted online, social media, and through a press release. The survey results are attached and the Board is encouraged to review and provide additional feedback.

## FINANCIAL IMPACT

---

None

## ATTACHMENTS

---

None

## SUGGESTED DIRECTION

---

Participate in discussion of the results and share ideas for summer recreation programming.

# Q1 Please indicate how many people in each age group are represented in your household.

Answered: 58 Skipped: 0

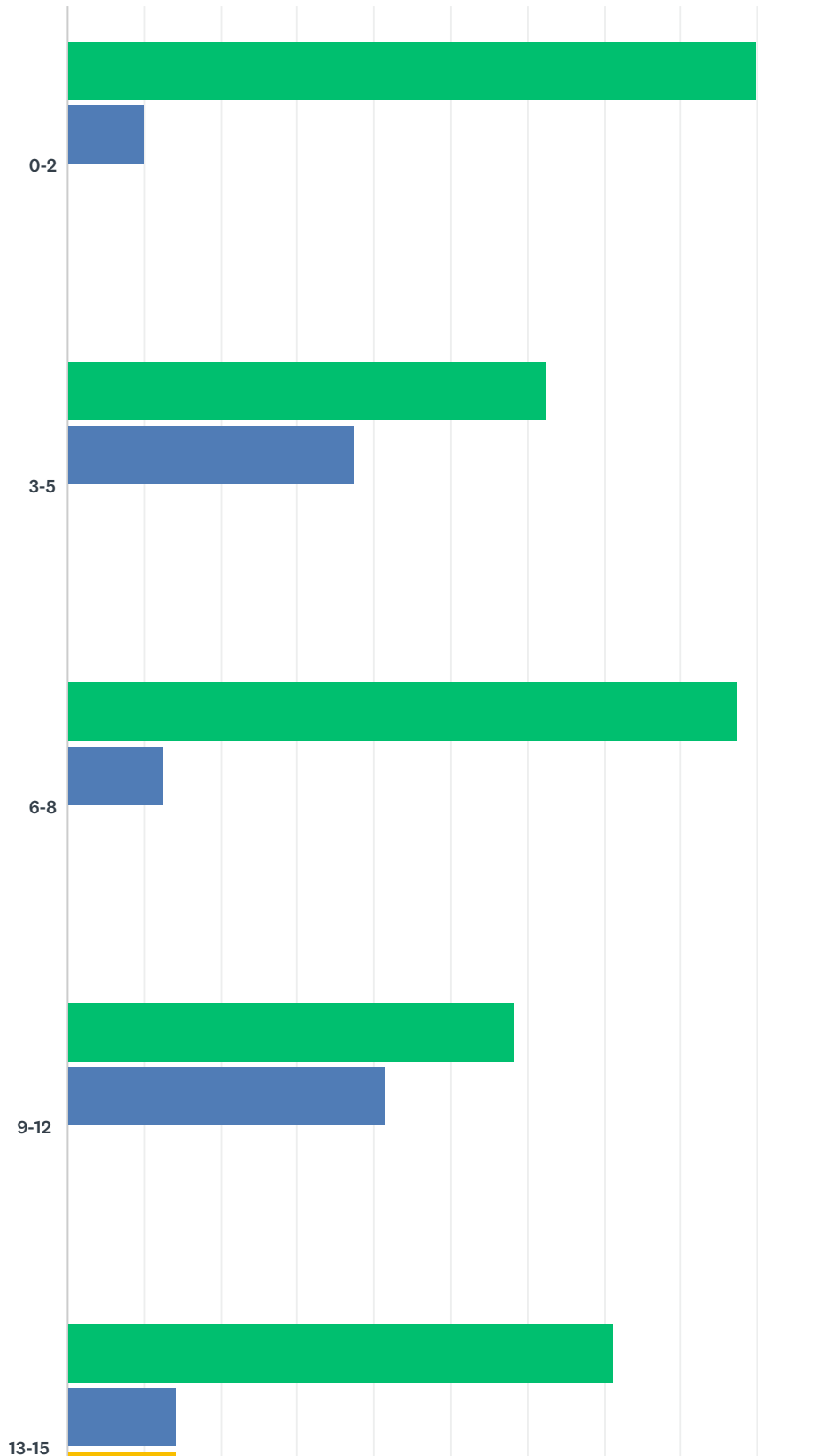

2019 Summer programs and events interest survey

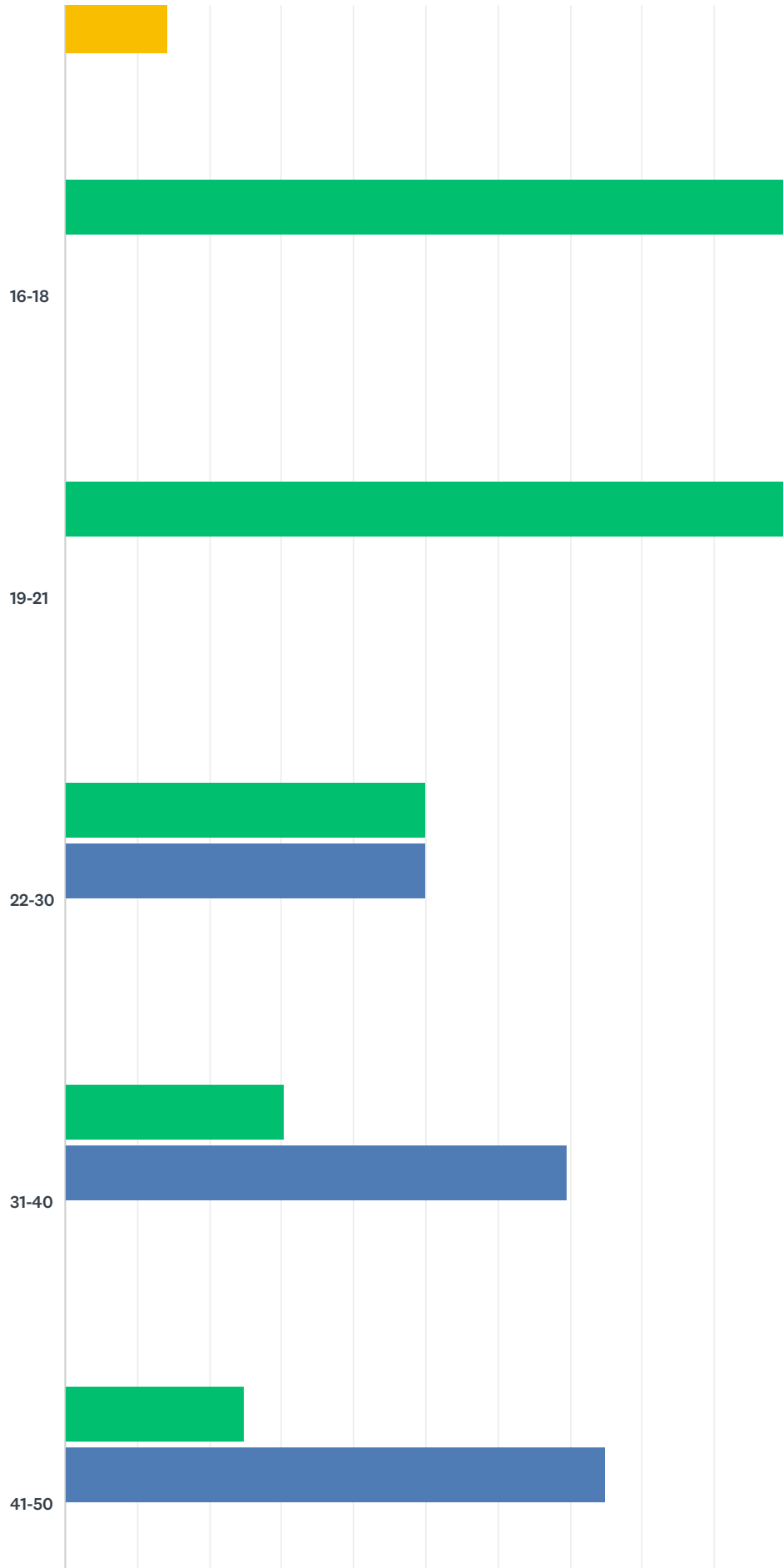

## 2019 Summer programs and events interest survey

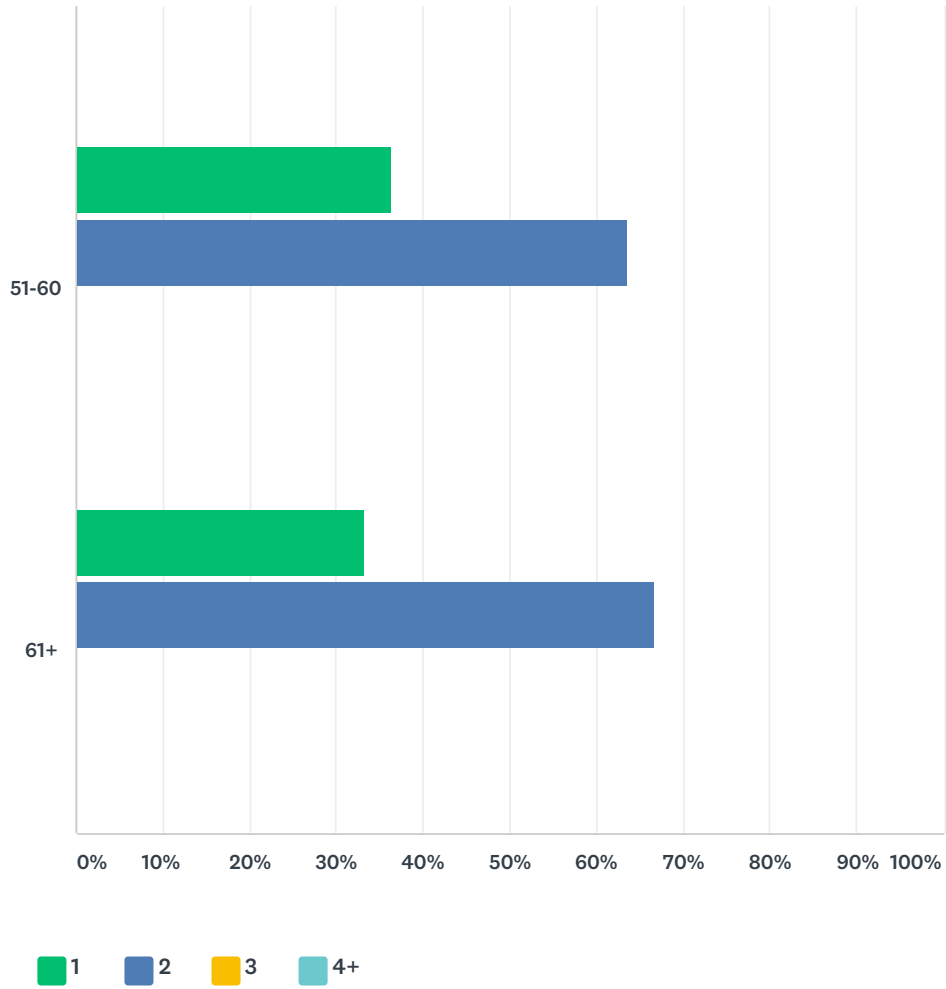

	1	2	3	4+	TOTAL
0-2	90.00% 9	10.00% 1	0.00% 0	0.00% 0	10
3-5	62.50% 10	37.50% 6	0.00% 0	0.00% 0	16
6-8	87.50% 14	12.50% 2	0.00% 0	0.00% 0	16
9-12	58.33% 7	41.67% 5	0.00% 0	0.00% 0	12
13-15	71.43% 5	14.29% 1	14.29% 1	0.00% 0	7
16-18	100.00% 4	0.00% 0	0.00% 0	0.00% 0	4
19-21	100.00% 2	0.00% 0	0.00% 0	0.00% 0	2
22-30	50.00% 3	50.00% 3	0.00% 0	0.00% 0	6
31-40	30.43% 7	69.57% 16	0.00% 0	0.00% 0	23
41-50	25.00% 5	75.00% 15	0.00% 0	0.00% 0	20
51-60	36.36% 4	63.64% 7	0.00% 0	0.00% 0	11

## 2019 Summer programs and events interest survey

---

61+	33.33%	66.67%	0.00%	0.00%	
	3	6	0	0	9

Q2 Last summer we held Neighborhood Park Fun Days at Stoneybrook, Ford School, Echo, Lynn Dillow, and Cattail Parks. Of the parks listed below, please select your top 4 choices for the 2019 Park Fun Days.

Answered: 58 Skipped: 0

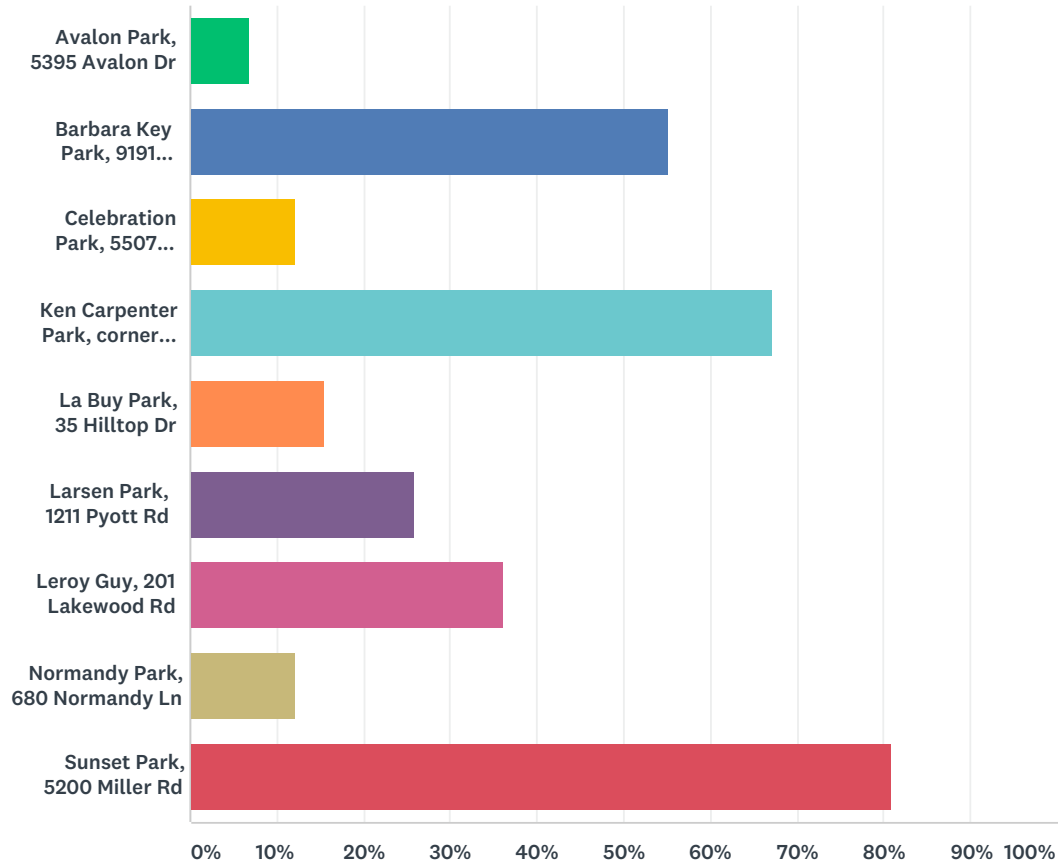

ANSWER CHOICES	RESPONSES
Avalon Park, 5395 Avalon Dr	6.90% 4
Barbara Key Park, 9191 Pyott Rd	55.17% 32
Celebration Park, 5507 McKenzie Dr	12.07% 7
Ken Carpenter Park, corner of Miller and Randall	67.24% 39
La Buy Park, 35 Hilltop Dr	15.52% 9
Larsen Park, 1211 Pyott Rd	25.86% 15
Leroy Guy, 201 Lakewood Rd	36.21% 21
Normandy Park, 680 Normandy Ln	12.07% 7
Sunset Park, 5200 Miller Rd	81.03% 47
Total Respondents: 58	

### Q3 Please select your top 4 choices for entertainment at the Park Fun Days

Answered: 57 Skipped: 1

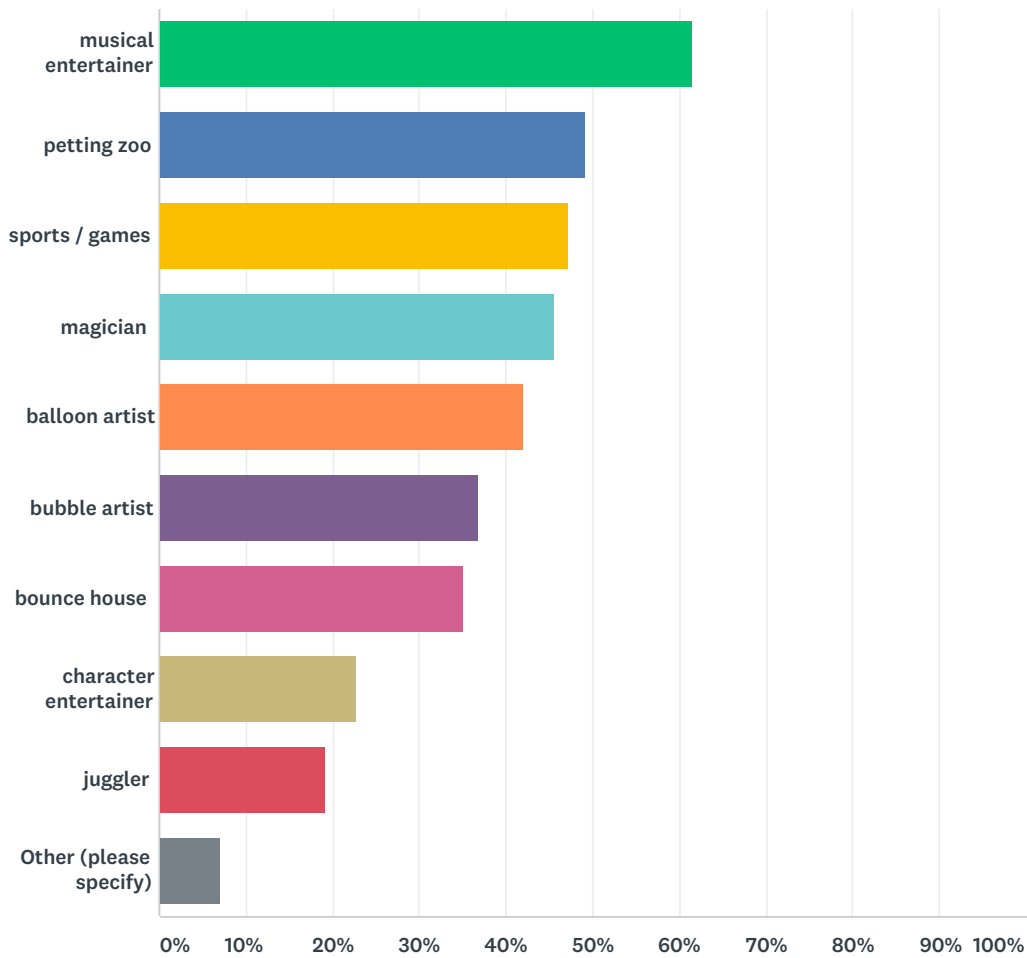

ANSWER CHOICES	RESPONSES	
musical entertainer	61.40%	35
petting zoo	49.12%	28
sports / games	47.37%	27
magician	45.61%	26
balloon artist	42.11%	24
bubble artist	36.84%	21
bounce house	35.09%	20
character entertainer	22.81%	13
juggler	19.30%	11
Other (please specify)	7.02%	4

## 2019 Summer programs and events interest survey

Total Respondents: 57

#	OTHER (PLEASE SPECIFY)	DATE
1	group exercise	1/17/2019 2:28 PM
2	Live music! It's the 50th Anniversary of WOODSTOCK!	1/14/2019 10:38 AM
3	Face paint	1/11/2019 4:49 PM
4	Games like skee ball	1/10/2019 8:22 PM



## Q4 What events or programs, offered by other organizations, have you participated in that you think would be a good fit for our community?

Answered: 34 Skipped: 24

#	RESPONSES	DATE
1	Sports camp for pre-k / preschool	1/28/2019 9:36 AM
2	Health fair	1/26/2019 7:49 AM
3	Many families I know pay NR to attend Nature Tots in Crystal Lake. I tried to bring a similar program to our area but my team was unsuccessful (Tinkergarten). I'm a leader on a local admin page and one area of programming regularly asked about is 0-5, specifically 0-3. Any programs, besides Tot Rock, that you can offer preschoolers and younger. My son did the one session offered of TBall last summer and wanted more. This age group is constantly searching for classes and events.	1/26/2019 4:08 AM
4	Don't know	1/25/2019 4:50 PM
5	I would love to see more events at Indian Trail Beach.	1/24/2019 7:07 PM
6	Adult sport leagues, outdoor concerts	1/19/2019 1:54 PM
7	Flashlight Easter Egg Hunt for Adults, Dog Blessing, Oktoberfest, Old Fashioned "Family Picnic"	1/17/2019 2:28 PM
8	free	1/17/2019 10:26 AM
9	Food Truck Festivals	1/17/2019 8:21 AM
10	mother son event, evening concerts in the park	1/15/2019 8:49 PM
11	Nerf battles and parents night out (cheaper than \$20 a kid). Dundee Park District has a great Saturday Live program for \$10 a child. It would be nice to save something like that close to home.	1/15/2019 7:57 AM
12	none	1/14/2019 2:35 PM
13	Senior yoga classes.	1/14/2019 2:01 PM
14	More free events for the kids and to bring the community together. Maybe do movies @ the park. Community cookouts.	1/14/2019 11:17 AM
15	Love going to Naper Nights, also events like Thursday nights with Live music like in Grayslake and Mt. Prospect.	1/14/2019 10:38 AM
16	Na	1/14/2019 6:53 AM
17	Community days with bounce houses and a bbq to get to know our neighbors.	1/14/2019 12:31 AM
18	Bring back sunset 5k !	1/13/2019 10:00 PM
19	Soccer or baseball for kids	1/13/2019 8:44 PM
20	Family scavenger hunts taking families to each of our parks and introducing them to what each park offers	1/13/2019 6:19 PM
21	Nothing	1/13/2019 5:09 PM
22	Movies in the park, kids concert in the park	1/13/2019 4:46 PM
23	Outdoor music concerts that aren't at the village hall where there is no shade. Yoga classes that have more than one day at one time per week	1/13/2019 7:46 AM
24	The family friendly concerts offered at village hall were great. Splash pad parties. Storytelling festival.	1/11/2019 11:01 PM
25	We used to love when the Hawaiian dancers came to Indian Trl Beach	1/11/2019 8:13 PM
26	—	1/11/2019 7:43 PM
27	Musicians	1/11/2019 5:35 PM

## 2019 Summer programs and events interest survey

28	Princesses and super hero's!	1/11/2019 4:49 PM
29	A 5k run	1/11/2019 10:58 AM
30	Very disappointed that you discontinued the CIT program and no longer allow children beyond 6th grade to participate. These children need a great place to go in the summer too so they are not home alone doing nothing. The CIT program was a great way for these kids to learn responsibility and grow in their leadership skills.	1/11/2019 10:38 AM
31	Women's softball league	1/10/2019 10:39 PM
32	Glow/color run	1/10/2019 9:49 PM
33	Adult softball league	1/10/2019 8:29 PM
34	Individual boxing Young male under 18 self defense Yoga for teens 15 And up	1/10/2019 8:22 PM

## Q5 Do you have any special skills or talents that you would like to share in the form of a program or class?

Answered: 26 Skipped: 32

#	RESPONSES	DATE
1	no	1/28/2019 9:36 AM
2	No sorry	1/26/2019 7:49 AM
3	I am a Tinkergarten leader/teacher.	1/26/2019 4:08 AM
4	Drum Lessons	1/25/2019 5:13 PM
5	No	1/25/2019 4:50 PM
6	No	1/24/2019 7:07 PM
7	I teach gardening at the Algonquin Lake in the Hills Food pantry	1/23/2019 5:13 PM
8	none	1/17/2019 2:28 PM
9	no	1/17/2019 10:26 AM
10	No	1/17/2019 8:21 AM
11	no	1/15/2019 8:49 PM
12	No	1/15/2019 7:57 AM
13	no	1/14/2019 2:35 PM
14	No.	1/14/2019 2:01 PM
15	Unfortunately No	1/14/2019 11:17 AM
16	I wish	1/14/2019 10:38 AM
17	No	1/14/2019 6:53 AM
18	No	1/14/2019 12:31 AM
19	Nadda	1/13/2019 10:00 PM
20	None.	1/13/2019 5:09 PM
21	—	1/11/2019 7:43 PM
22	No	1/11/2019 5:35 PM
23	No talents!	1/11/2019 4:49 PM
24	no	1/11/2019 10:58 AM
25	No	1/10/2019 10:39 PM
26	No	1/10/2019 8:29 PM

## Q6 If you would like to be contacted by our department to provide further input, please provide your contact information.

Answered: 6 Skipped: 52

ANSWER CHOICES	RESPONSES	
Name	100.00%	6
Company	0.00%	0
Address	0.00%	0
Address 2	0.00%	0
City/Town	100.00%	6
State/Province	0.00%	0
ZIP/Postal Code	0.00%	0
Country	0.00%	0
Email Address	100.00%	6
Phone Number	100.00%	6

#	NAME	DATE
1	Mindi Moran	1/26/2019 4:08 AM
2	Tony	1/25/2019 5:13 PM
3	Laurie	1/23/2019 5:13 PM
4	Doug James	1/14/2019 10:38 AM
5	Andrea Stangl	1/11/2019 10:38 AM
6	Nathan hyde	1/10/2019 8:29 PM

#	COMPANY	DATE
	There are no responses.	

#	ADDRESS	DATE
	There are no responses.	

#	ADDRESS 2	DATE
	There are no responses.	

#	CITY/TOWN	DATE
1	LAKE IN THE HILLS	1/26/2019 4:08 AM
2	Lake In The Hills	1/25/2019 5:13 PM
3	Lake In The Hills	1/23/2019 5:13 PM
4	LITH	1/14/2019 10:38 AM
5	Algonquin	1/11/2019 10:38 AM
6	Algonquin	1/10/2019 8:29 PM

#	STATE/PROVINCE	DATE
	There are no responses.	

2019 Summer programs and events interest survey

#	ZIP/POSTAL CODE	DATE
	There are no responses.	
#	COUNTRY	DATE
	There are no responses.	
#	EMAIL ADDRESS	DATE
1	mindimoran@gmail.com	1/26/2019 4:08 AM
2	Tonyl955@aol.com	1/25/2019 5:13 PM
3	lselpien@att.net	1/23/2019 5:13 PM
4	dougjames49@mac.com	1/14/2019 10:38 AM
5	andrea.stangl@firstmidwest.com	1/11/2019 10:38 AM
6	nathanielrhyde@gmail.com	1/10/2019 8:29 PM
#	PHONE NUMBER	DATE
1	8473872177	1/26/2019 4:08 AM
2	847-471-1751	1/25/2019 5:13 PM
3	2245580627	1/23/2019 5:13 PM
4	8472743461	1/14/2019 10:38 AM
5	847-514-6010	1/11/2019 10:38 AM
6	8158717515	1/10/2019 8:29 PM